

ZR Series

ZR22™ 2' x 2' LED Troffer

Product Description

The ZR22™ LED troffer delivers 3200 lumens of superior 90 CRI light quality and is perfect for both new construction and renovation. Powered by Cree TrueWhite® Technology, the slim and lightweight ZR22™ LED troffer boasts an efficacy of up to 150 LPW along with 0-10V dimming to meet local energy codes. The ZR22™ LED troffer embodies a breakthrough in balancing energy savings, visual comfort and initial cost.

Performance Summary

Utilizes Cree TrueWhite® Technology
Efficacy: 90-150 LPW
Initial Delivered Lumens: 3,200 lumens
Input Power: 21-35 watts
CRI: 90 CRI
CCT: 3500K, 4000K
Input Voltage: 120-277 VAC or 347 VAC
Limited Warranty*: 10 years
Controls: 0-10V dimming to 5%
Mounting: Recessed*

*See www.cree.com/lighting/products/warranty for warranty terms

Accessories

Field-Installed	
Drywall Grid Adapter DGA-22WHT	6' Flexible Power Whip PW-18/4-06-9T-SS
Surface Mount Kit SMK ZB22	
- Not for use with EB14	

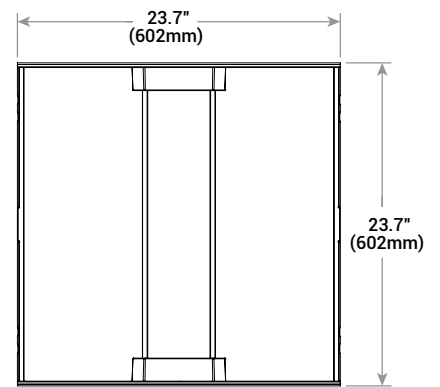
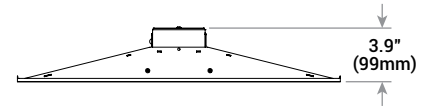

Ordering Information

Example: ZR22 32L 35K 10V

Product	Initial Delivered Lumens	CCT	Voltage	Control	Options
ZR22	32L 35W, 3200 Lumens – 90 LPW 32L HE 21W, 3200 Lumens – 150 LPW	35K 3500K 40K 4000K	Blank 120-277 Volt 34** 347 Volt	10V 0-10V Dimming 5%	EB14_Emergency Backup - 1,400 Lumens - Available on US versions only

* Acceptable for use with standard 9/16 T-Bar or larger when installed per installation instructions. Consult factory for non-standard grid applications
** Available with 32L only



Rev. Date: V2 11/09/2015



ZR22™ 2' x 2' LED Troffer

Product Specifications

CREE TRUEWHITE® TECHNOLOGY

A revolutionary way to generate high-quality white light, Cree TrueWhite® Technology is a patented approach that delivers an exclusive combination of 90+ CRI, beautiful light characteristics, and lifelong color consistency, all while maintaining high luminous efficacy – a true no compromise solution.

CONSTRUCTION & MATERIALS

- Durable cold rolled steel housing provides strength and uniformity
- Ultra-thin 4.9" (124mm) luminaire height and lightweight design effectively target a broad range of plenum spaces and allow for easy installations
- Luminaire is pre-painted for enhanced smooth finish
- Includes t-bar clips and holes for mounting support wires (by others)
- Luminaire sides and ends are hemmed in for safe, easy handling

OPTICAL SYSTEM

- Unique luminaire design creates perfect balance of both horizontal and vertical illumination
- Optimized smooth lens eliminates pixelation and delivers a low-glare, diffused light distribution

ELECTRICAL SYSTEM

- Cree born components including highly efficacious Cree® LED chips along with an integral high-efficiency Cree® driver
- **Power Factor:** = 0.9 nominal
- **Input Power:** Stays constant over life
- **Input Voltage:** 120-277V or 347V, 50/60Hz
- **Battery Backup:** Consult factory
- **Operating Temperature Range:** 0°C - +35°C (32°F - +95°F)
- **Total Harmonic Distortion:** <20%

CONTROLS

- Continuous dimming to 5% with 0-10V DC control protocol
- For use with Class 2 dimming systems only. Reference www.creelink.com/exLink.asp?70982140Z58R34I26620963 for recommended dimming controls and wiring diagrams

REGULATORY & VOLUNTARY QUALIFICATIONS

- UL924 (EB option)
- cULus listed
- Suitable for damp locations
- Designed for indoor use and outdoor covered applications
- DLC qualified when ordered with 32L type. Please refer to www.designlights.org/QPL for most current information
- RoHS compliant. Consult factory for additional details
- Meets FCC Part 15 standards for conducted and radiated emissions

Application Reference

Open Space						
Spacing	Initial Delivered Lumens	Lumens	Wattage	LPW	w/ft²	Average fc
8 x 8	32L HE	3,200	21	150	0.40	56
	32L		35	90	0.66	56
8 x 10	32L HE	3,200	21	150	0.33	46
	32L		35	90	0.55	46
10 x 10	32L HE	3,200	21	150	0.26	37
	32L		35	90	0.44	37
10 x 12	32L HE	3,200	21	150	0.21	30
	32L		35	90	0.35	30

9' ceiling: 80/50/20 reflectances; 2.5' workplane, open room. LLF: 1.0 Initial Open Space: 50' x 40' x 10'

Photometry

ZR22-32L-35K BASED ON CESTL REPORT TEST #: 2014-0006

Luminaire photometry has been conducted by a NVLAP accredited testing laboratory in accordance with IESNA LM-79-08. IESNA LM-79-08 specifies the entire luminaire as the source resulting in a luminaire efficiency of 100%.

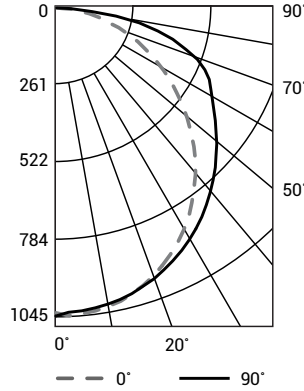

Average Luminance Table (cd/m²)				
		Horizontal Angle		
		0°	45°	90°
Vertical Angle	45°	2,740	2,927	3,131
	55°	2,564	2,943	3,339
	65°	2,358	3,111	3,631
	75°	2,101	3,614	4,600
	85°	1,757	3,468	4,184

Coefficients Of Utilization – Zonal Cavity Method				
RC %:	80			
RW %:	70	50	30	10
RCR: 0	119	119	119	119
1	107	102	97	93
2	97	88	81	74
3	88	77	68	61
4	80	68	58	51
5	74	60	51	43
6	68	54	45	38
7	63	49	40	33
8	59	45	36	29
9	55	41	32	26
10	51	38	30	24

Effective Floor Cavity Reflectance: 20%

Zonal Lumen Summary			
Zone	Lumens	% Lamp	Luminaire
0-30	808	N/A	24.7%
0-40	1,328	N/A	40.5%
0-60	2,394	N/A	73.1%
0-90	3,274	N/A	100%
0-180	3,274	N/A	100%

Reference lighting.cree.com/products/indoor/troffers/zr-series for detailed photometric data

Recommended ZR Series Lumen Maintenance Factors (LMF) ¹						
Ambient	Initial Delivered Lumens	Initial LMF	25K hr Projected ² LMF	50K hr Calculated ^{2,3} LMF	75K hr Projected ² LMF	100K hr Calculated ³ LMF
0°C (32°F)	32L HE	1.05	1.01	0.98	0.96	0.94
	32L	1.05	0.99	0.95	0.91	0.87
5°C (41°F)	32L HE	1.04	1.00	0.97	0.95	0.93
	32L	1.04	0.98	0.94	0.90	0.86
10°C (50°F)	32L HE	1.03	0.99	0.96	0.94	0.92
	32L	1.03	0.97	0.93	0.89	0.85
15°C (59°F)	32L HE	1.02	0.98	0.95	0.93	0.91
	32L	1.02	0.96	0.92	0.88	0.84
20°C (68°F)	32L HE	1.01	0.97	0.95	0.92	0.90
	32L	1.01	0.95	0.91	0.87	0.83
25°C (77°F)	32L HE	1.00	0.96	0.94	0.91	0.89
	32L	1.00	0.95	0.90	0.86	0.83
30°C (86°F)	32L HE	0.99	0.95	0.93	0.91	0.89
	32L	0.99	0.94	0.89	0.86	0.82
35°C (95°F)	32L HE	0.98	0.94	0.92	0.90	0.88
	32L	0.98	0.93	0.89	0.85	0.81

¹ Lumen maintenance values at 25°C are calculated per TM-21 based on LM-80 data and in-situ luminaire testing

² In accordance with IESNA TM-21-11, Projected Values represent interpolated value based on time durations that are within six times (6X) the IESNA LM-80-08 total test duration (in hours) for the device under testing (DUT) i.e. the packaged LED chip

³ In accordance with IESNA TM-21-11, Calculated Values represent time durations that exceed six times (6X) the IESNA LM-80-08 total test duration (in hours) for the device under testing (DUT) i.e. the packaged LED chip

