

Lunera T-LED Lamp Family: Engineered for Quality & Reliability

Engineering Best-of-Class T-LED Lamps

Lunera's T-LED Lamp family is engineered to be the best-of-class, setting the industry benchmark for quality, reliability and performance. They deliver the expected, general benefits of an LED lamp including significant energy savings, 50K+ hours long life, maintenance free operation and near full-spectrum, high CRI quality light.

But they have incorporated engineering breakthroughs that enhance the performance, quality and reliability of the products (Table 1). This application note introduces these engineering breakthroughs which set's Lunera's T-LED lamps apart from others.

Table 1. Engineering Breakthroughs

Flexible LED PCB & Driver Electronics
LED Selection
Glass Tube Construction
Thermal Fuse Protection
Universal Tombstone Technology (UTT)

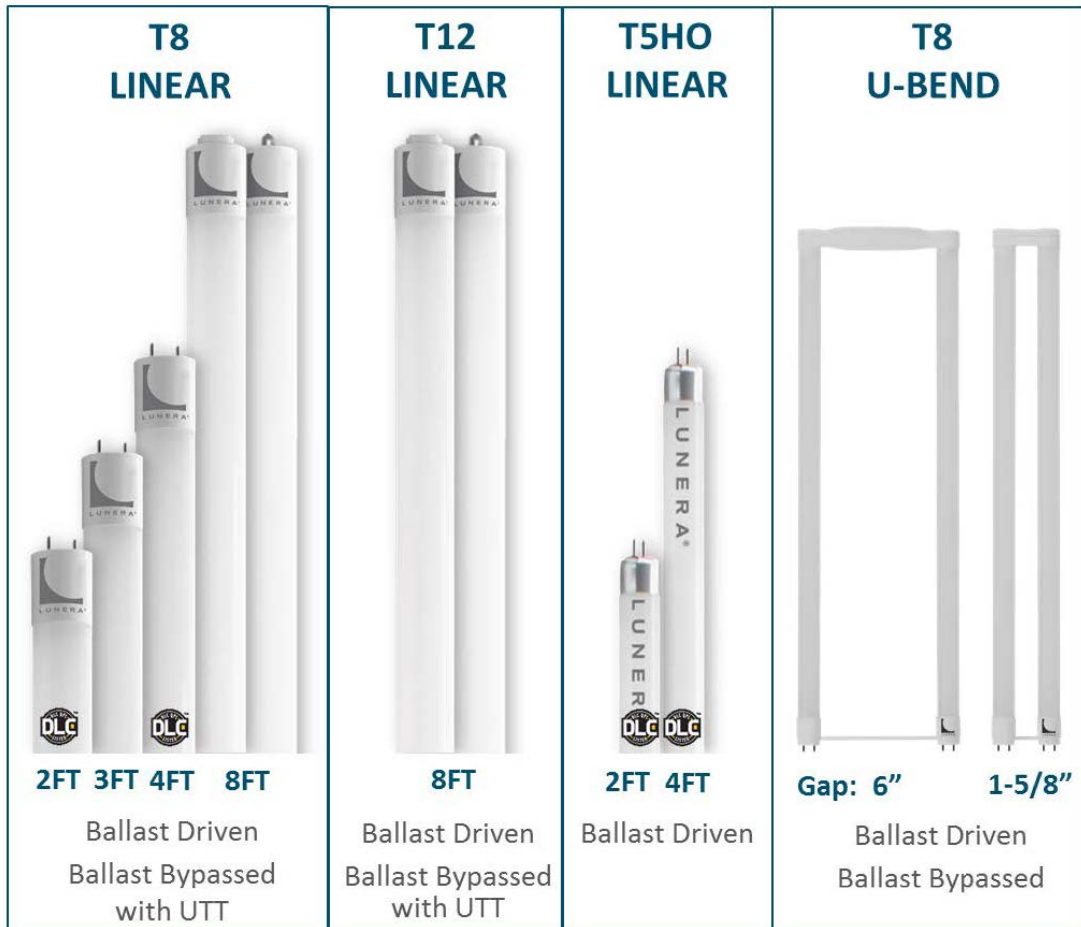

Lunera T-LED Lamp Family: Engineered for Quality and Reliability

Breakthrough 1: Electronics

Customer satisfaction is often derived from elements of a product that aren't seen, whereas a failure in design definitely leads to customer dissatisfaction. In Lunera's family of T-LED lamps, the innovation in the electronics package and components aren't seen, but represent a key component to a premium product experience.

Linear Lamp Electronics Package

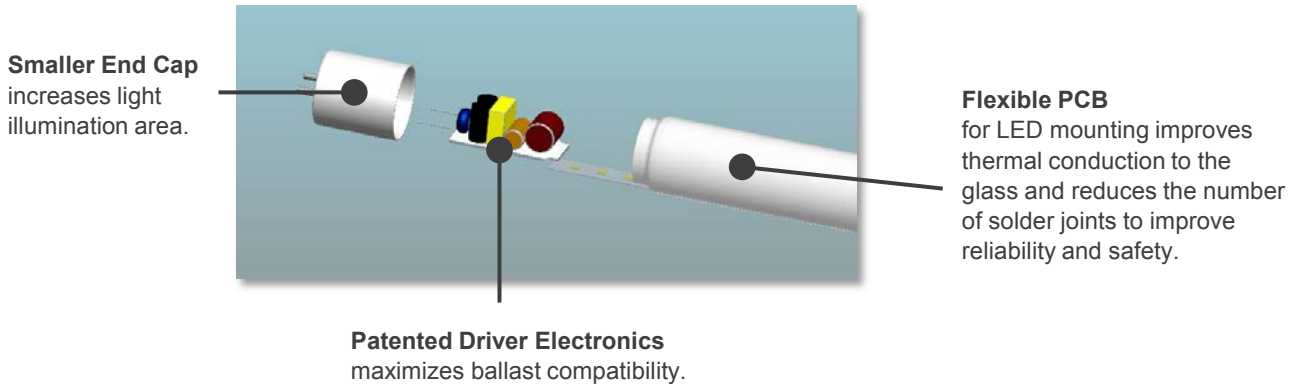

The electronics of Lunera's linear LED lamps are designed for superior performance, quality and reliability.

Driver Circuitry

Lunera invented plug and play LED lamps for commercial lighting, launching our first ballast-driven products in 2013.

One of the greatest sources of customer dissatisfaction with ballast-driven T-LEDs is poor ballast compatibility. Lunera leads the industry in T-LED ballast compatibility. Lunera's linear LED lamps have been tested for compatibility in over 200 ballasts and are compatible with Instant-Start, Rapid-Start, and Programmed-Start ballasts.

Furthermore, the compact design of the electronics package helps to minimize the T-LED end cap size and maximize the illuminated area of the tube.

Flexible PCB Assembly

Switching from a rigid to a flexible LED PCB eases soldering, improves thermal conduction to the glass, makes the lamp lighter, and improves safety in the event of glass breakage.

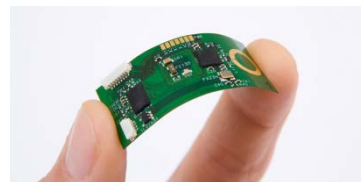

Breakthrough 2: LEDs



Selection

Lunera uses high-performance LED chips which are then enclosed in a robust package and finished with a top-quality phosphor to ensure a long life with exceptional performance.

Throttle Back the Driver

Heat kills LEDs. Together with an optimized thermal design, we keep the LEDs in the Lunera T-LED lamps running cool at less than 40% of their rated drive. This keeps the LED current and junction temperature low, which improves efficacy and extends the lamp lifetime.



Breakthrough 3: Glass Tube

Better Glass

Lunera's T-LED lamps are constructed of premium glass tubes coated using a proprietary diffusion technology that does not age, yellow or crack and delivers superior optical efficacy with outstanding lumen maintenance.

Our glass tubes do not bend. The exacting manufacturing process toughens the glass tube and includes end necking and sealed end caps, just as a fluorescent tube would have. This strengthens the overall design and resists breakage.

Lunera's glass is dramatically better than plastic as shown in the following tables. Our glass offers distinct advantages over many other vendor's glass tubes as well.

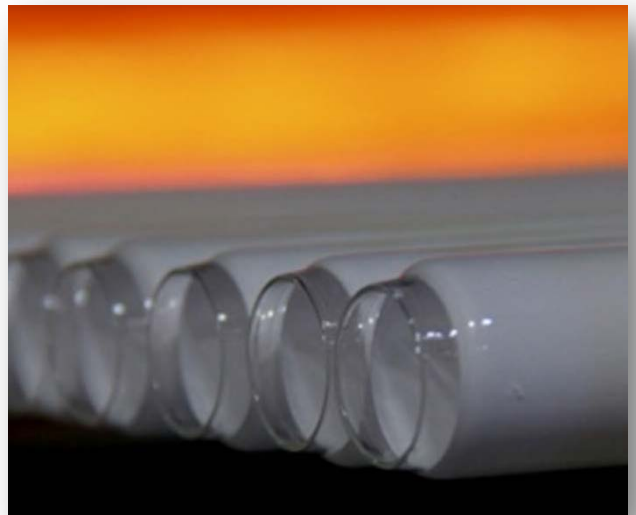

Lunera T-LED Lamp Family: Engineered for Quality and Reliability

Lunera Glass Compared to Plastic T-LED Tubes

	Lunera Glass	Plastic
Perception	Classic design, valuable	Plain, cheap
Performance		
Optical Efficacy	92%	88%
Lumen Maintenance	Lasting	Degrades
Thermal Management	Thinner , high melting temperature	Thicker, lower melting temperature
Safety & Reliability		
Flammability/Arcing	No	Yes
Bending	No	Yes
Yellowing	No	Yes
Cracking	No	Yes

Lunera Glass Compared to Other T-LED or Fluorescent Glass Tubes

	Lunera Glass	Other Glass
Material	Fine white pure sand	Sands with other elements/chemicals
Processing		
Glass Furnace	Electric – high precision control	Coal/Gas – Instable process control
End Necking (end form)	Yes – strengthens the end, which is the weak point	No
Toughening	Yes	No
Capping	High strength seal	Low strength glue
Coating	Proprietary diffusion that does not yellow, age, or crack	May yellow, age, or crack in 2-3 years

330 Degrees of Uniform Light Distribution

The optics of the tube plays a key role in how closely the T-LED lamp matches the appearance of the fluorescent lamp it is replacing.

We've optimized the optical design for a beam angle of $\sim 330^\circ$ which makes the light output as close to a fluorescent as possible, perfectly fitting existing fixtures and delivering uniform light across space.

Lunera Glass v. Plastic

Plastic Tube

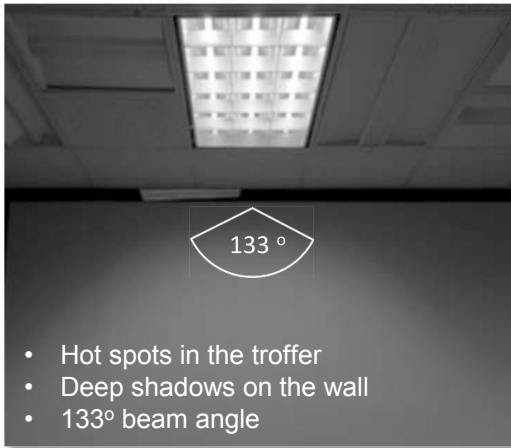

Lunera Glass

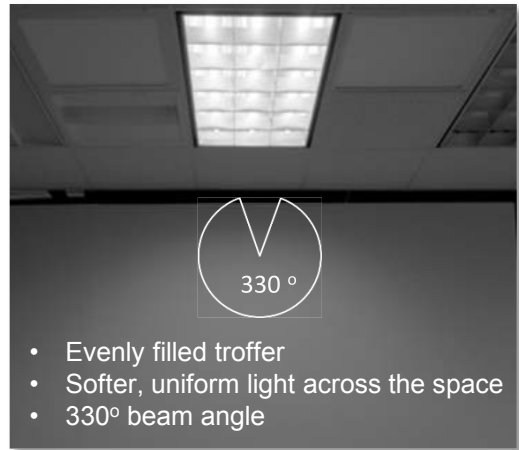

Breakthrough 4: Thermal Fuse Protection on Ballast Driven Lamps

The introduction of a Thermal Fuse Protection in our Ballast Driven T-LED lamps protects a facility from a dramatic lamp failure.

All Lunera's T-LEDs have a disabling fuse on each of the 4 pins. The latest models have an additional Thermal Fuse on the electronics board as the last line of defense.

Thermal Fuse



Under certain conditions including arcing, which may occur if the ballast has been improperly wired, the thermal fuses will open, permanently disabling the lamp and preventing overheating and melting.

The melting threshold of the fuses is lower than that of the lamp, thus ensuring that the lamp will disable safely.

Lunera T-LED Lamp Family: Engineered for Quality and Reliability

Breakthrough 5: Universal Tombstone Technology on Line Driven Lamps

Lunera's Universal Tombstone Technology (UTT) integrates electronics in the Ballast Bypassed (120V-277V) LED T8 lamps.

UTT eliminates the risk of shock while handling the lamp during installation by limiting current leakage at the Neutral end of the lamp.

Lunera's Ballast Bypassed (Type-B) T8 LEDs are the first double-ended T8 LED lamps to receive UL Certification.

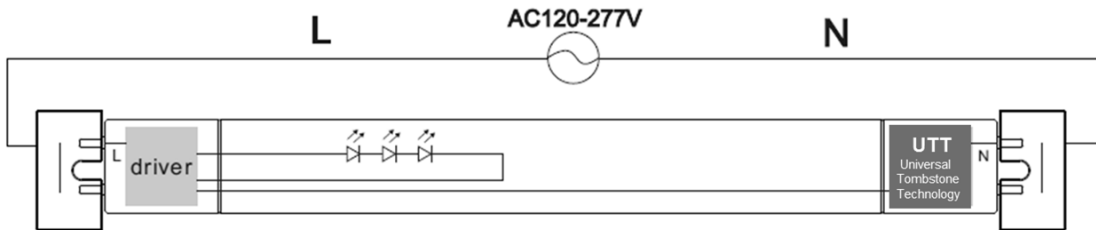

In addition to being certified safe by UL, another benefit from Universal Tombstone Technology is that the ballast bypassed T-LED lamp can now be installed in fixtures using either shunted or non-shunted tombstones.

This simplifies the retrofit process by eliminating the need to rewire the fixture or replace shunted tombstones with non-shunted versions.

Simply bypass or remove the ballast and install the lamps. This is estimated to reduce installation time up to 50%.

Wiring examples are shown on the following page.



Non-shunted

Shunted

Wiring Simplified with Lunera Ballast Bypassed T-LEDs with UTT

Instant Start Ballast

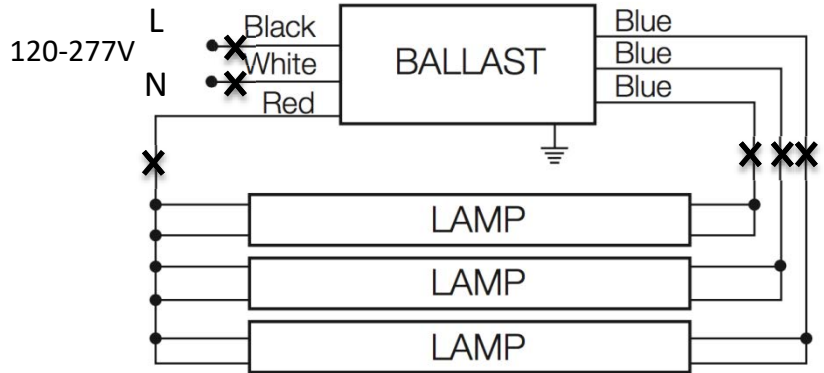

Program Start Ballast

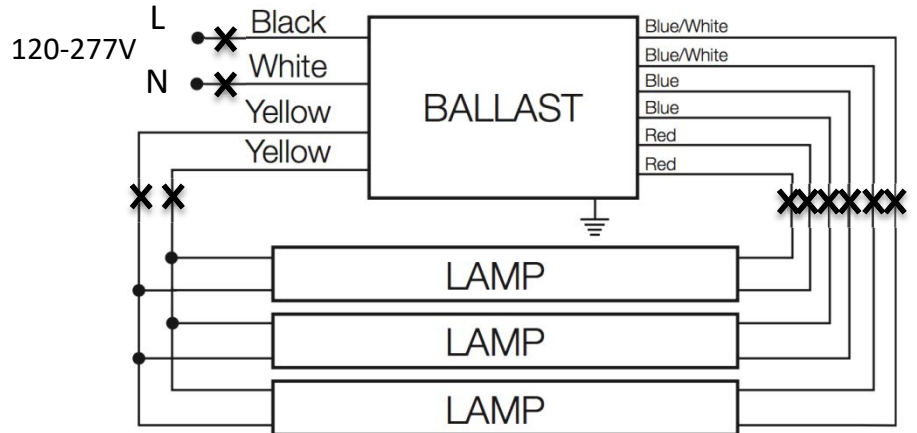

120-277V

