

### IMPORTANT SAFEGUARDS

When using electrical equipment, basic safety precautions should always be followed including the following:

### READ AND FOLLOW ALL SAFETY INSTRUCTIONS

- 1. DANGER-** Risk of shock- Disconnect power before installation.
- This luminaire must be installed in accordance with the NEC or your local electrical code. If you are not familiar with these codes and requirements, consult a qualified electrician.
- Suitable for Damp Locations.
- Access above ceiling required. Do not install insulation within 3 inches (76 mm) of any part of the luminaire. Suitable for suspended ceilings.
- Do not handle energized module with wet hands or when standing on wet or damp surfaces, or in water

### SAVE THESE INSTRUCTIONS FOR FUTURE REFERENCE

- The ZR Series of recessed troffers is for non-insulated ceiling applications using T-Bar ceiling grid, drywall grid adaptors, and suspended mount.
- Designed for use in 120-277V 50-60 Hz or 347V 60Hz protected circuit (fuse box, circuit breaker). Supply wire sized as per NEC or governing code(s), 90C rated.
- Make sure to cap off all unused leads.
- \*\* Not intended for use with 9/16" T-Bar grids unless used with a 9/16" accessory clip like "Armstrong® LFC- Fixture Clip" which can be purchased through distribution. Consult factory for non-standard grid applications.

### TO INSTALL:

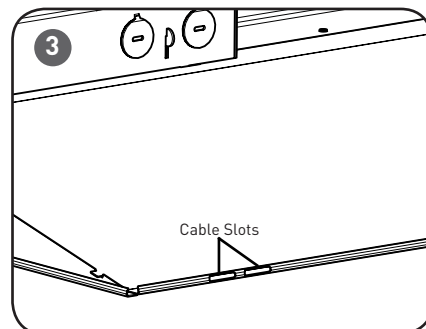
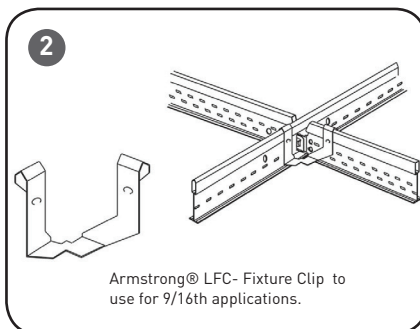
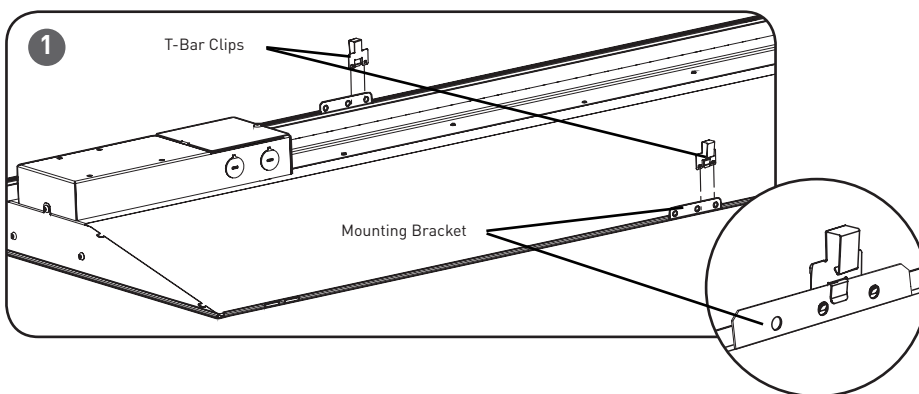

### INSTALLATION INSTRUCTIONS

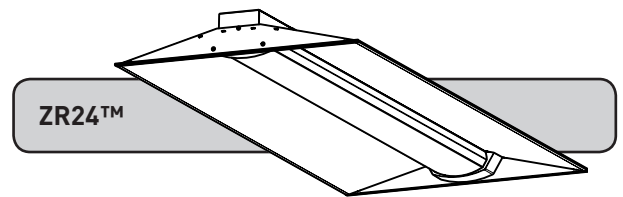
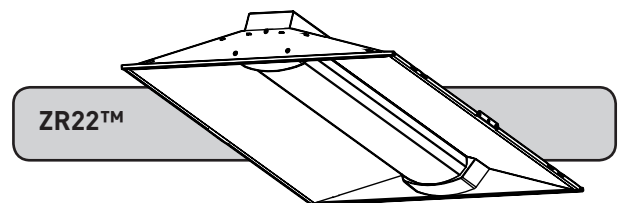
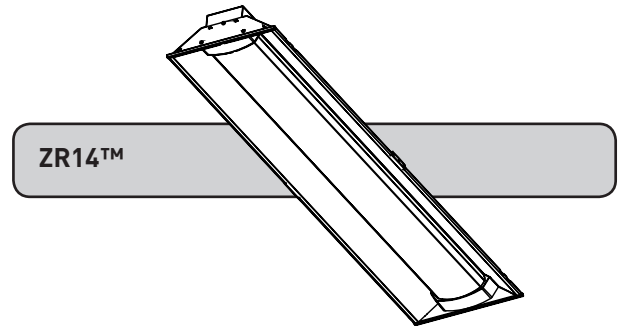

### T- BAR CEILING MOUNTING

#### STEP 1:

Install the (2) supplied T-Bar clips onto the mounting bracket on the outside of the housing. See **Figure 1 and 2.**

#### STEP 2:

Bring the ZR troffer into the T-Bar Ceiling panel and attach the clips on the housing onto the T-Bar.

### SUSPENDED MOUNTING

#### STEP 1:

Attach customer supplied cables to the (2) cable slots on each corner of the housing. See **Figure 3.**

#### STEP 2:

Attach customer supplied cables to mounting surface using customer supplied hardware. Ensuring that mounting surface can support the luminaire.

## 0 - 10V DIMMING OPTION

### STEP 1:

Remove the cover of the junction box and bring in appropriate power supply to the junction box using one of the knock-outs. See **Figure 4 and 5**.

**NOTE:** Do NOT use the third knock-out that is shown in **Figure 5**.

### STEP 2:

Bring dimming conduit into dimming wire compartment using the knock-out. See **Figure 5**.

### STEP 3:

Wire luminaire per “**Electrical Connections**” section and push all leads into the junction box. Reattach junction box cover that was removed in Step 1, make sure no wires are pinched.

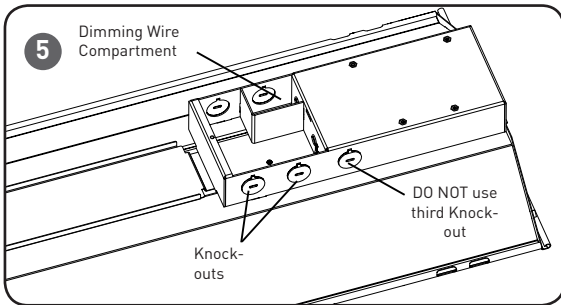
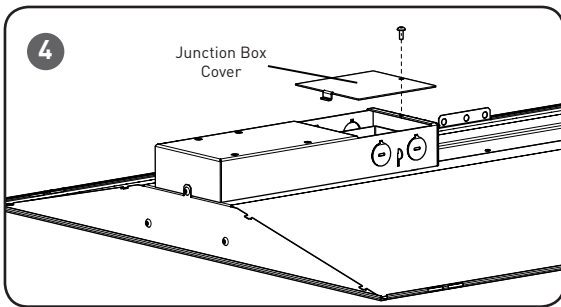

## ELECTRICAL CONNECTIONS

### STEP 1:

Make the following Electrical Connections:

- Connect the black fixture lead to the voltage supply Line position, Hot.
- Connect the white fixture lead to the neutral supply position.
- Connect the green or green/yellow ground lead to the supply ground lead.
- If 0/1-10V Dimming is used, connect the violet lead to the supply positive dimming lead. If dimming is not being used ensure to cap off the violet lead.
- If 0/1-10V Dimming is used, connect the gray lead to the supply negative dimming lead. If dimming is not being used ensure to cap off the gray lead.

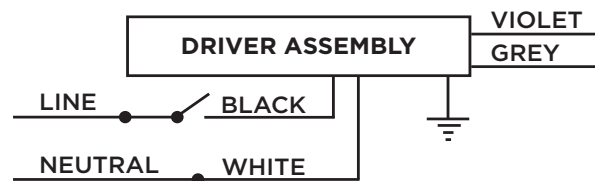

## FCC NOTICE

**CAUTION:** Changes or modifications not expressly approved could void your authority to use this equipment.

This device complies with Part 15 of the FCC Rules. Operation to the following two conditions: (1) This device may not cause harmful interference, and (2) this device must accept any interference received, including interference that may cause undesired operation.

This device has been tested and found to comply with the limits for a Class A digital device, pursuant to Part 15 of the FCC Rules. These limits are designed to provide reasonable protection against harmful interference when the device is operated in a commercial environment. This device generates, uses, and can radiate radio frequency energy and, if not installed and used in accordance with the instruction manual, may cause harmful interference to radio communications. Operation of this device in a residential area is likely to cause harmful interference in which case the user will be required to correct the interference at his own expense.

## INDUSTRY CANADA STATEMENT

This device complies with Industry Canada licence-exempt RSS standard(s). Operation is subject to the following two conditions: (1) this device may not cause interference, and (2) this device must accept any interference, including interference that may cause undesired operation of the device. In addition, this device complies with ICES-003 of the Industry Canada (IC) Regulations.