

## SPECIFICATION SHEET: FHSCP-UNV-5WL

This Is An Original Product From Fulham Co., Inc

**Description:** Emergency LED Driver - Output 5W (Constant) - Universal Voltage - 100-250mA - 20-50V Forward Voltage - Long Case with Wire

**This Driver Will Operate The Following LED Modules:**

Any LED module designed to accept constant input current of 100-250mA and that has a forward input voltage range of 20-50VDC.

### ELECTRICAL DATA

Input Voltage	120-277VAC, 50/60Hz
Input Current	0.061A Max.
Input Power	3.9W
Output Current	100-250mA
Output Voltage Range	20-50Vdc
Output Power/ Lumens	5W (Constant)/ 800lm
Battery Type/ Model Number	Ni-Cd 4.8Vdc
Battery Capacity Available	13.4WH
Recharge Time	24 Hours
Number of Output Channels	1
RFI/EMI	FCC Part 15A Non-Consumer
Output Type	Class 2
Ambient Operating Temperature Range	0°C to 50°C
Surge Protection	Per C62.41 (TVS)
Protections	Input Overcurrent Protection (Fusible link)
Service Life	50,000 Hours
Approvals / Class	ULus Class 2; Damp Locations

### MECHANICAL DATA

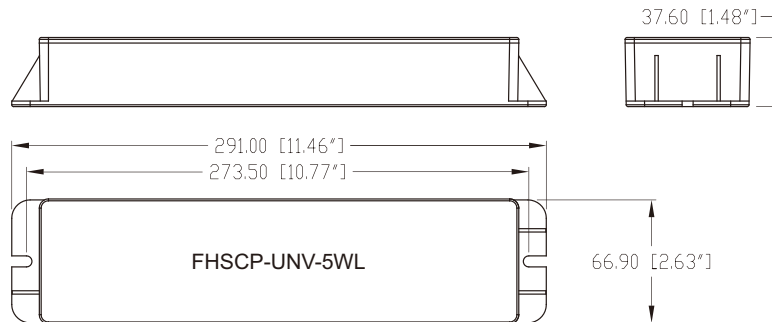

Tolerance=±0.02"

**NOTE : This Driver Must Be Grounded**

### WIRING DIAGRAMS

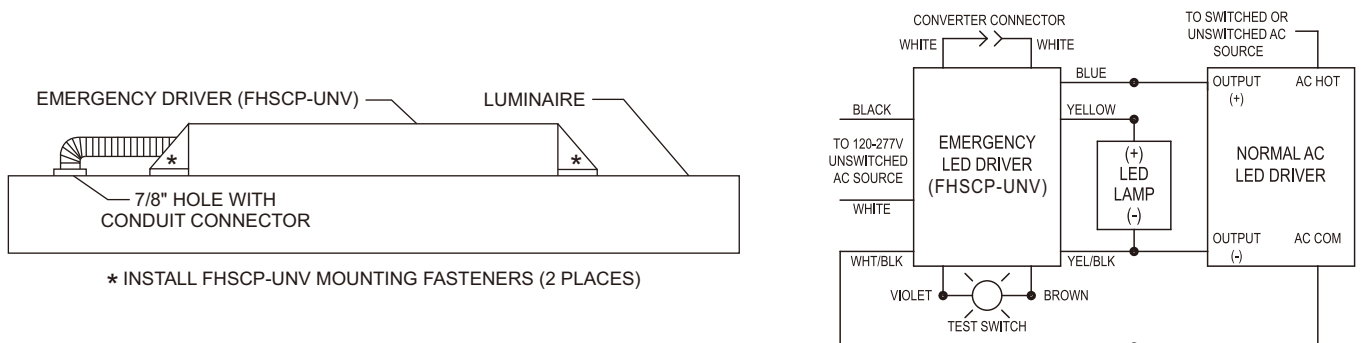

Fulham extends a limited warranty only to the original purchaser or to the first user for a period of **5 years** from the date of manufacture when properly installed and operated under normal conditions of use. For complete terms and conditions, please reference the Fulham Product Catalog. Due to a program of continuous improvement, Fulham reserves the right to make modifications or variations in design or construction to the equipment described. © Fulham Company Limited, All Rights Reserved.