

# BR30 Series

LED Reflector Lamps

## Product Description

At Cree®, we believe in better lighting. Better light is beautiful light. But it's more than just beautiful. It is light that makes you feel more productive, more relaxed and safer. Better light changes everything. That's why the new and improved Cree LED bulbs feature high color rendering that enhances your space and makes the colors of your décor appear vibrant, richer and more natural – true colors the way they are meant to be experienced.

The Cree LED BR30 flood light casts a beautiful light that looks and lights like the incandescent bulbs you love. Dimmable with most standard dimmers, Cree LED BR30 flood lights shine wide and bright while using at least 88% less energy, and are designed to deliver up to 25,000 hours of light for your home or business. The perfect replacement for incandescent bulbs in track and recessed fixtures at a price you can afford, Cree LED bulbs pay for themselves quickly and then pay you year after year.

## Performance Summary

<b>Lamp Delivered Light Output:</b> 665-670 lumens
<b>Input Power:</b> 7-8 watts (65W equivalent)
<b>CRI:</b> 85
<b>CCT:</b> 2700K, 5000K
<b>Limited Warranty*:</b> 5 years Commercial use
<b>Lifetime:</b> Designed to last at least 25,000 hours
<b>Dimming:</b> Dimmable to 5% with select dimmers
ENERGY STAR® Certified
Must order in multiples of master carton (MC) quantities; MC = (4) 3-Lamp Multi-Packs (12 Total Lamps)

\*See <http://lighting.cree.com/warranty> for warranty terms

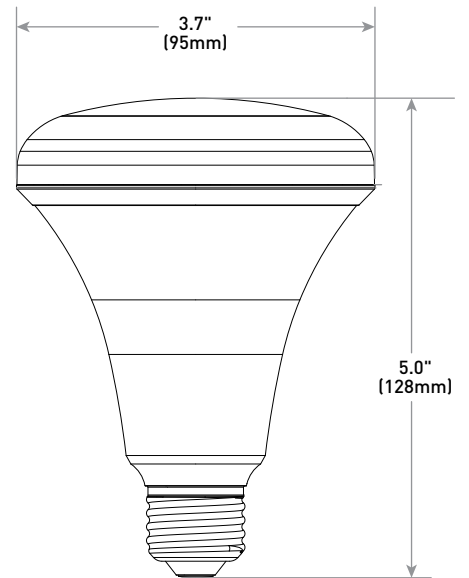

## Ordering Information

Example: BR30-65W-27K-M3

Product	Watt Equivalent	CCT	Voltage	Base	CRI	Packaging Options
BR30	65W 65 Watt, 665-670 lumens	27K 2700K 50K 5000K	Blank 120 Volt	Blank E26 (screw base)	Blank 85	M3 (1) 3-Lamp Multi-Pack; MC = (4) 3-Lamp Multi-Packs (12 Total Lamps)



Rev. Date: V9 09/14/2016



## BR30 Series LED Reflector Lamps

### Product Specifications

#### CONSTRUCTION & MATERIALS

- BR30 reflector bulb design weighs 4.0 ounces (115g)
- Reflector bulb meets ANSI standards for BR30 dimensions
- Uses a standard E26 screw base
- Mercury free

#### OPTICAL SYSTEM

- Plastic globe offers increased optical spread

#### ELECTRICAL SYSTEM

- **Power Factor:** > 0.9 nominal
- **Input Voltage:** 120V, 60Hz
- **Dimming:** Dimmable to 5% with select dimmers. Refer to <https://www.creelink.com/viewcontent.asp?qv=1&docid=5344> for additional details
- **Operating Temperature Range:** -25°C - +45°C (-13°F - +113°F)

#### REGULATORY & VOLUNTARY QUALIFICATIONS

- cULus Listed
- Suitable for damp locations, but not for use where exposed directly to weather or water
- Suitable for use in enclosed light fixtures. Lifetime may be reduced if used in air tight enclosures or in insulated ceiling air tight (ICAT) recessed downlight enclosures
- ENERGY STAR® certified. Please refer to <http://www.energystar.gov/productfinder/product/certified-light-bulbs/> results for most current information  
BR30-65W-27K-M3: SBR30-06527FLFD-12DE26-1-11  
BR30-65W-50K-M3: SBR30-06550FLFD-12DE26-1-11
- Meets FCC Part 15, Subpart B, Class B standards for conducted and radiated emissions
- RoHS compliant. Consult factory for additional details

### Packaging

(4) 3-Lamp Multi-Packs in Master Carton (12 Total Lamps)



Ordering Number	Product Number	3-Lamp Multi-Pack UPC	Description	Bulb Type	Watts	CCT	3-Lamp Multi-Packs per Master Carton	Master Carton ITF-14	Total Lamps per Master Carton	Master Cartons Per Pallet Qty*	CRI	Lumens	Rated Life (Hrs)
BR30-65W-27K-M3	SBR30-06527FLFD-12DE26-1-13004S0	849665011347	65W Soft White BR30 Equivalent	BR30	8	2700K	4	10849665011344	12	70	85	665	25,000
BR30-65W-50K-M3	SBR30-06550FLFD-12DE26-1-13004S0	849665011361	65W Daylight BR30 Equivalent	BR30	7	5000K	4	10849665011368	12	70	85	670	25,000

\* 280 Multi-Packs per pallet