



Item#: **PLT-10746**
LANDSCAPE LIGHTING
 BRASS AVALON HAMMERED HOODED PATHWAY

The Avalon Pathway light is a heavy duty low voltage outdoor fixture.

FEATURES

- PTFE 250C, 300V, Teflon wire with half strip included
- Silicone Wire Nuts are included

APPLICATION

Ideal for parking lots, street and building perimeter lighting.

ELECTRICAL

Supported Lamp Type	JC
Voltage	12V
Base	G4

LIGHTING PERFORMANCE

Beam Angle	90°
Dimmable Lighting Control	

ENVIRONMENT

Suitable Location	WET
Ingress Protection Rating	IP44

LIFESPAN

Warranty (Years)	5
------------------	----------

CONSTRUCTION

Housing	Brass / PC
Lens	Clear
Base / Power Supply	Hard Wired
Finish	Bronze

DIMENSIONS (Inches)

Length	--
Width/Diameter	6.9"
Height	23.5
Weight (Lbs)	--

Line drawings may not be to scale and are for general reference only.

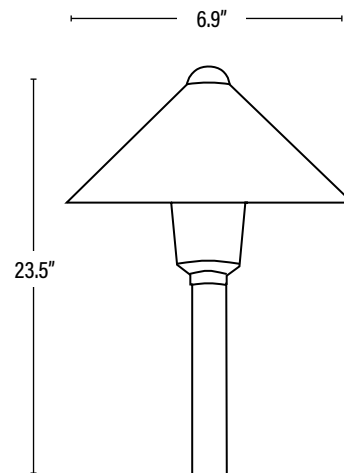

Item#: **PLT-10746**
LANDSCAPE LIGHTING

PACKAGING		UPC	DIMENSIONS (LxWxH)	GROSS WEIGHT (Lbs)
Master Carton	20	10811768027874	--	--
Individual Box	1	811768027877	--	--
Country of Origin	China			
HS Tariff	9405.40.6000			

ORDERING

ITEM#	DESCRIPTION	CASE
PLT-10746	BRASS AVALON HAMMERED HOODED PATHWAY/G4/12V - W/PLASTIC SPIKE	20

ACCESSORIES/REPLACEMENT PARTS

PLT-10748	BRASS MOUNTING BASE	50
PLT-10749	ABS MOUNTING STAKE FOR LANDSCAPE FIXTURES	100
PLT-10750	LARGE PVC MOUNTING STAKE FOR LANDSCAPE FIXTURES	100