

# SPECIFICATION

## 50W LED DRIVER

Issued date: January 20, 2013

REV: V1.0

Model: SS-50R

Description: 50W AC to DC LED DRIVER

Customer: \_\_\_\_\_

Customer Approval Signature	SHENZHEN SOSEN ELECTRONICS CO LTD		
	WRITTEN	CHECKED	APPROVED
	LING CAIMENG January 20, 2013	LUO GENSHUI January 20, 2013	ZYWANG January 20, 2013

**SHENZHEN SOSEN ELECTRONICS CO LTD**

**Table 1  
Table of Content**

<b>1. Applications</b> .....	<b>4</b>
<b>2. Features</b> .....	<b>4</b>
<b>3. Input parameter</b> .....	<b>4</b>
3.1 Rated AC input range .....	<b>4</b>
3.2 AC input range .....	<b>4</b>
3.3 Input Current/AC .....	<b>4</b>
3.4 Input inrush current(cold start).....	<b>4</b>
3.5 Power factor .....	<b>4</b>
<b>4. Output</b> .....	<b>4</b>
4.1 Selection model list .....	<b>4</b>
4.2 Turn - on Delay Time .....	<b>5</b>
4.3 Hold-up Time.....	<b>5</b>
4.4 Rise Time .....	<b>5</b>
4.5 Fall Time .....	<b>5</b>
4.6 Output Overshoot / Undershoot .....	<b>5</b>
<b>5. PROTECTION FUNCTION</b> .....	<b>5</b>
5.1 Output over-voltage protection .....	<b>5</b>
5.2 Output over-current Protection.....	<b>6</b>
5.3 Short Circuit Protection .....	<b>6</b>
<b>6. Environment requirement</b> .....	<b>6</b>
6.1 Operating Temperature .....	<b>6</b>
6.2 Storage Temperature .....	<b>6</b>
6.3 Relative Operation Humidity .....	<b>6</b>
6.4 Relative Storage Humidity .....	<b>6</b>
6.5 Cooling Method .....	<b>6</b>
6.6 Vibration .....	<b>6</b>
6.7 Height Above Sea Level .....	<b>6</b>
<b>7. Reliability Requirements</b> .....	<b>6</b>
7.1 Burn-in .....	<b>6</b>
7.2 MTBF Estimation .....	<b>7</b>
<b>8. EMI/EMS Standards</b> .....	<b>7</b>
<b>9. Safety Standards</b> .....	<b>7</b>
9.1 Dielectric Strength(Hi-pot) .....	<b>7</b>
9.2 Leakage Current .....	<b>7</b>
9.3 Insulation Resistance.....	<b>7</b>
9.4 Regulatory Standards.....	<b>7</b>
<b>10. Dimension</b> .....	<b>8</b>
<b>11. Product Weight</b> .....	<b>8</b>
<b>12. Label</b> .....	<b>8</b>
<b>13. Wire Specification</b> .....	<b>9</b>
<b>14. Mechanical Drawing</b> .....	<b>9</b>
<b>15. Block Diagram</b> .....	<b>9</b>
<b>16. Reliability Curve</b> .....	<b>10</b>
<b>17. Static Characteristics</b> .....	<b>10</b>
<b>18. Package Drawing</b> .....	<b>11</b>

**【1. Applications】**

- LED Signage / Channel Letter
- LED Architectural Lighting
- LED Commercial Industrial Lighting
- LED General Luminaries



图 1/ Figure 1

**【2. Features】**

- ◆ Constant Current
- ◆ Suitable for dry and wet Outdoor Environment, Waterproof IP66
- ◆ Plastic shell
- ◆ CE, TUV, UL, SAA approved
- ◆ Active PFC Function
- ◆ Suitable for indoor

**【3. Input】**

- 3.1 Rated AC input range: 100---240Vac/50---60Hz
- 3.2 AC input range: 90---277Vac/50---60Hz
- 3.3 Input AC Current/AC: 0.5Amax. @ 100---277Vac input & Full load
- 3.4 Input inrush current(cold start): ≤25A at 110Vac ≤15A at 230Vac
- 3.5 Power factor: ≥0.95 ( at full load, 115Vac/230Vac )

**【4. Output】**

4.1 Model Listing

NO	MODEL	Output Voltage		Output current	Output current tolerance	Ripple & Noise	Output power	Short-circuit power	Efficiency	Certificate
		No-load Voltage	Full load Voltage	Full load current						
1	SS-50R-36	37V ±3%	24---36V	1500mA max	±3%	2000mVmax	50W	≤5W	≥85%	TUV/UL/CUL/CE
2	SS-50R-36A	37V ±3%	24---36V	1300mA max	±3%	2000mVmax	50W	≤5W	≥85%	TUV/CE
3	SS-50R-36B	37V ±3%	24---36V	1200mA max	±3%	2000mVmax	50W	≤5W	≥85%	TUV/CE
4	SS-50R-36-C	37V ±3%	24---36V	1500mA max	±3%	2000mVmax	50W	≤5W	≥85%	无
5	SS-50R-36-D	37V ±3%	24---36V	1500mA max	±5%	2000mVmax	50W	≤5W	≥85%	无
6	SS-50R-50-C	51V ±3%	35---50V	1050mA max	±3%	2000mVmax	50W	≤5W	≥85%	无

**Table 2**

Ripple & Noise: Measurement is done by 20MHz bandwidth oscilloscope and the output paralleled a 0.1uF ceramic capacitor and a 10uF electrolysis capacitor. (test under the condition of rated input and rated output)

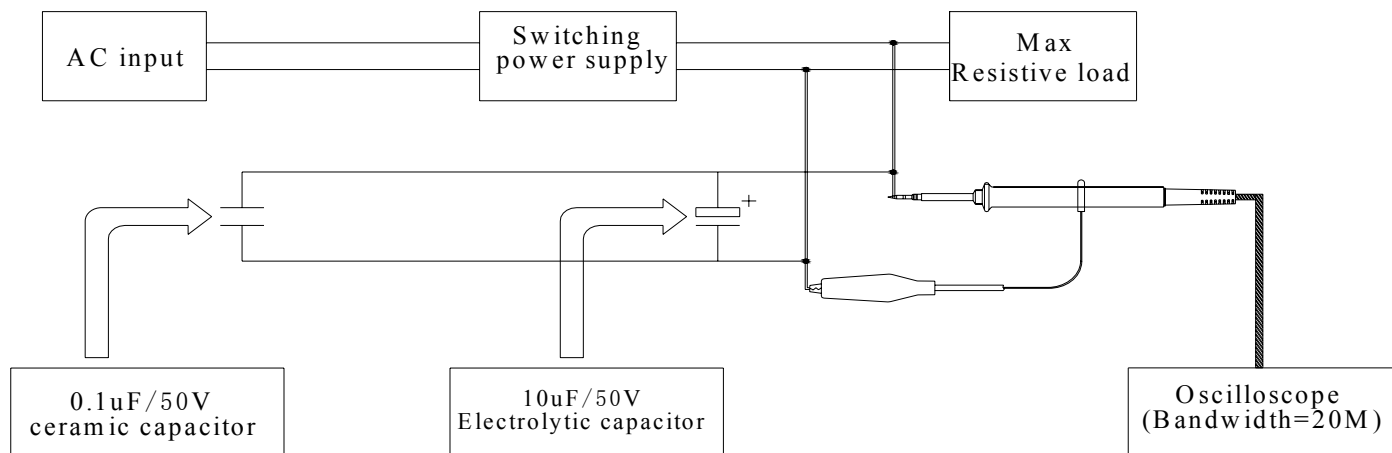

**Figure 2**

**4.2 Turn - on Delay Time**

3S max. @ 230 Vac input & full load.

**4.3 Hold-up Time**

10mS min. @ full load & 230Vac/50Hz input turn off at worst case.

**4.4 Rise Time**

100mS max. @ full load.

**4.5 Fall Time**

50mS max. @ full load.

**4.6 Output Overshoot / Undershoot**

10% max. When the power on or off

**【5. PROTECTION FUNCTION】**

**5.1 Output Over- Voltage Protection**

When the output voltage exceeds 10% of the rated voltage , the driver is protected such as hiccup or remaining at the highest point of output voltage so the driver would not be damaged. When the fault is excluded or restart, the driver works normally.

**5.2 Output Over-Output Current Protection**

When the output currents is over 130%, hiccup protection will be activated. Automatic recovery is supported.

**5.3 Short Circuit Protection**

The input power shall decrease when the output rail short, the power supply shall no damage, and shall be self-recovery when the fault condition is removed

## **【6. Environment requirement】**

- 6.1 Operating Temperature  
-35°C to +50°C
- 6.2 Storage Temperature  
-40°C to +85°C
- 6.3 Relative Operation Humidity  
10%RH to 100%RH
- 6.4 Relative Storage Humidity  
5%RH to 100%RH
- 6.5 Cooling Method  
Air Cooling
- 6.6 Vibration  
1.0mm, 10 –25Hz, 15 minutes per cycle for each axis (X, Y, Z)
- 6.7 Height Above Sea Level  
The driver can normally operate at -65~4000 meters.

## **【7. Reliability Requirements】**

- 7.1 Burn-in  
The power supply shall be burn-in for 4 hours at 40°C±5°C (The detail is at suggest Test Standard).
- 7.2 MTBF Estimation  
The MTBF shall be at least 30,000hours at 50°C, 100% load at rated input condition.

**【8. EMI/EMS Standards】**

8.1 EMI Standards

EN55015:2006+A1:2007+A2:2009	Refer to table 2
EN61547:2009	Refer to table 2
EN61000-3-2:2006+A1:2009+A2:2009	Refer to table 2
EN61000-3-3:2008	Refer to table 2

**Table 3**

**【9. Safety Standards】**

9.1 Dielectric Strength(Hi-pot)

Primary to Secondary: 3000Vac/5mA Max/60 seconds (3seconds for production).

9.2 Leakage Current

3.5mA 3.5mA max.

9.3 Insulation Resistance

10MΩ min. at primary to secondary adds 500Vdc test voltage.

9.4 Regulatory Standards

Type	Country	Standard	State	Mark
CE	Europe	EN61347-1:2008+A1:2011 EN61347-2-13:2006	Refer to table 2	
TUV	Europe	EN61347-1:2008+A1:2011 EN61347-2-13:2006	Refer to table 2	
UL /CUL	North American	UL8750	Refer to table 2	
CQC	China	GB17625-1 GB7743	Refer to table 2	

**Table 4**

**【10. Dimension】**

10.1 L95mm\*W70mm\*H32mm

**【11. Product weight】**

11.1 Weight : about 330 gram

**【12. Label】**

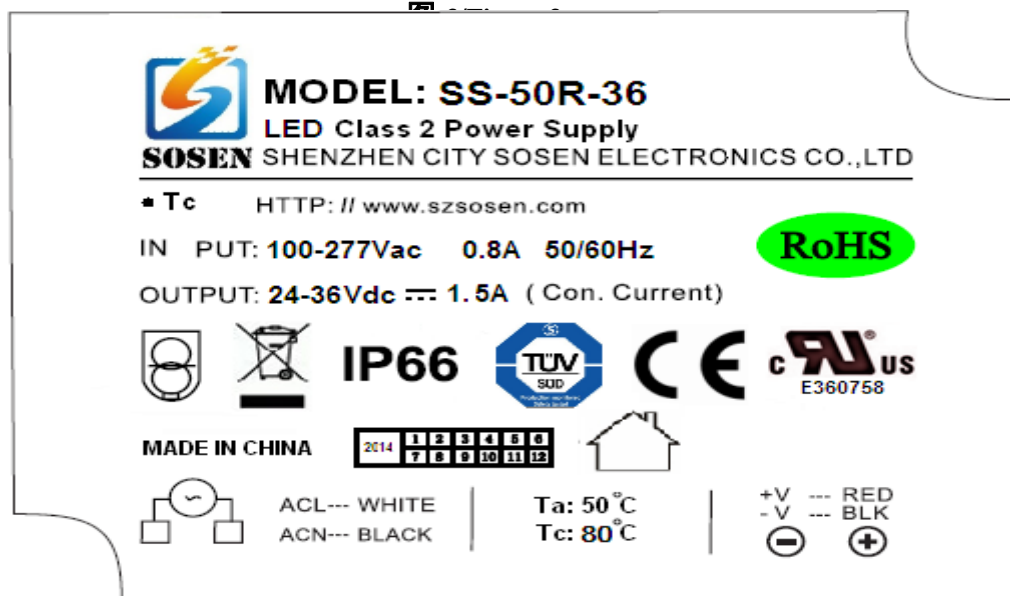
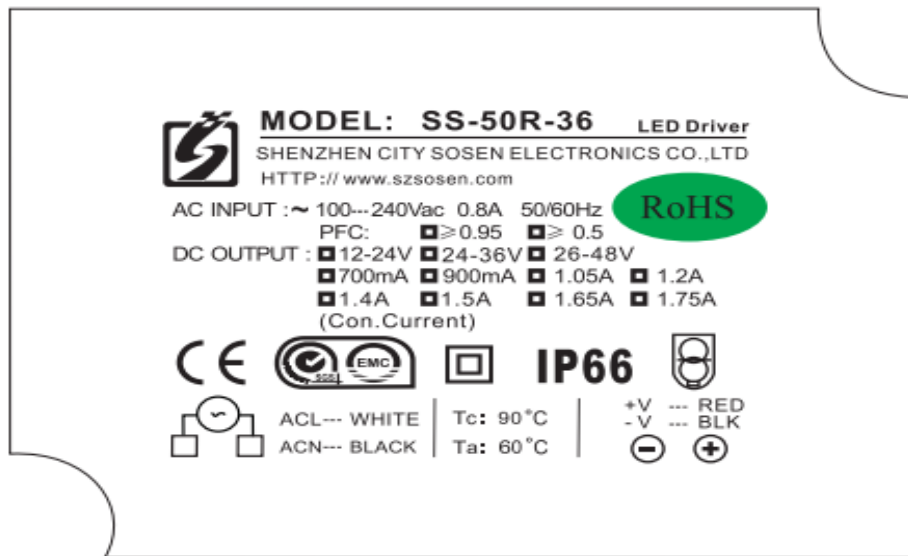
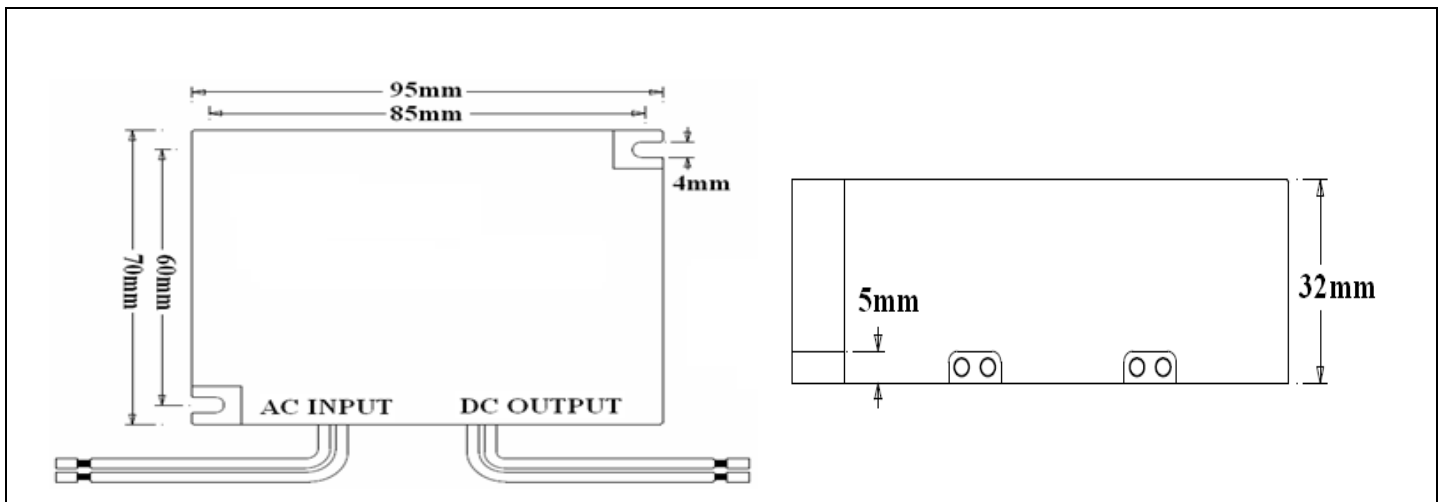

**Figure 4**

**【13. Wire Specification】**

1. AC input line: Black and white wire: 1015 # and 18AWG 105 °C wire stripping tin 8 mm exposed 170 mm
2. DC output line : Red and black wire: 1430 # and 18AWG 105 °C wire stripping tin 8 mm exposed 170 mm

**【14.Mechanical Drawing】**



**Figure 5**

**【15.Block Diagram】**

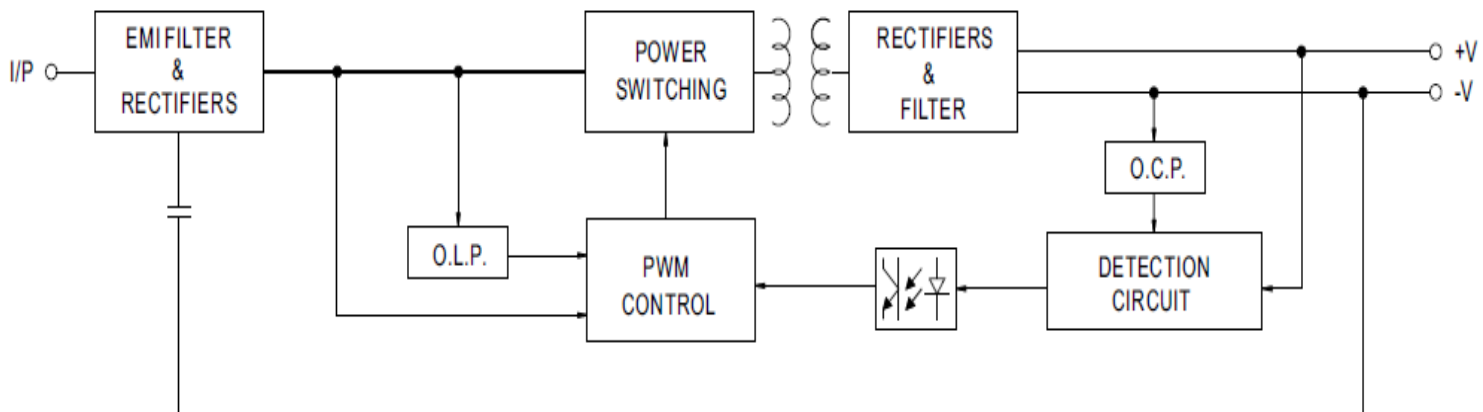

**Figure 6**



**【16. Reliability Curve】**

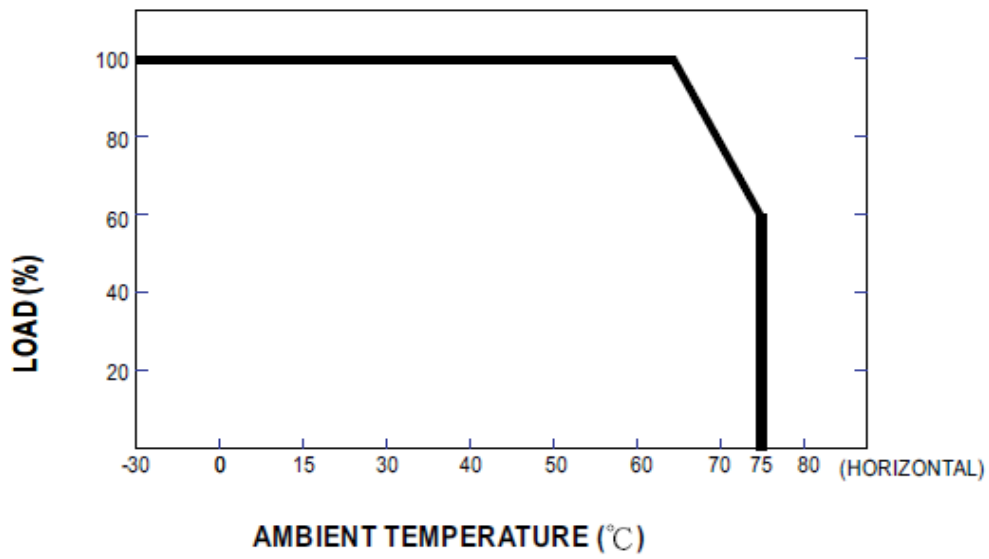

Figure 7

**【17. Static Characteristics】**

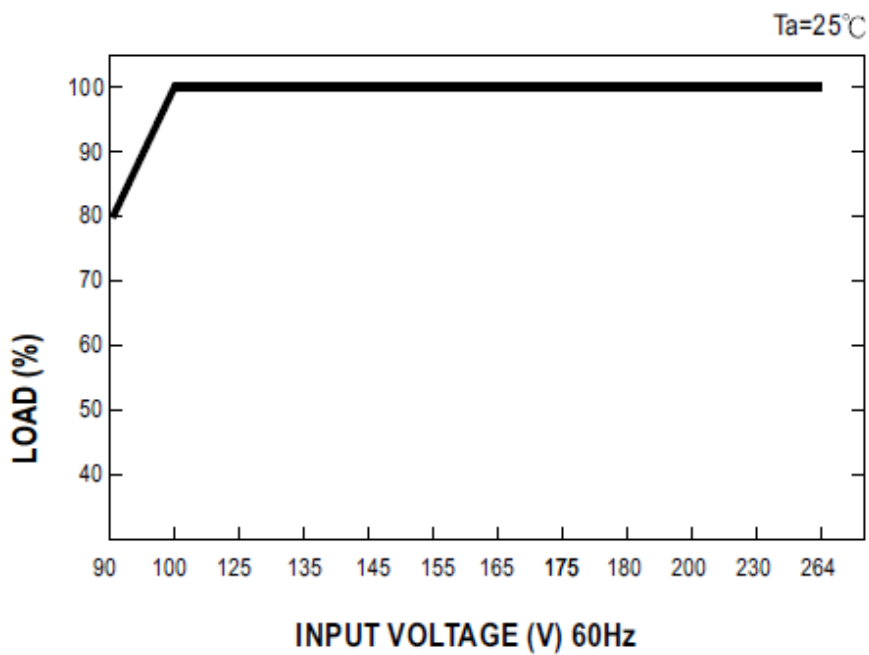
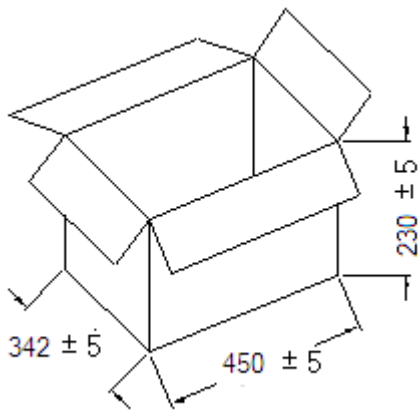

Figure 8

**【18. Package】**



**Figure 9**

Technical requirement:

1. Carton ;
2. Outside carton size: L522\*W234\*H230mm;
3. Environment request: RoHS approved;
4. Exterior appearance request: no damage, no dirt, no edges incision;
5. Each carton: 56pcs;