

INSTALLATION INSTRUCTION

AC-LED LEDme® Light Bars

BA-ACLED8, BA-ACLED12, BA-ACLED18, BA-ACLED24, BA-ACLED30

WAC LIGHTING
Responsible Lighting®

SAFETY INSTRUCTION

IMPORTANT: NEVER attempt any work without shutting off the electricity.

- Read all instructions before installing.
- System is intended for installation by a qualified electrician in accordance with the National Electrical Code and local regulations.
- Go to the main fuse box, or circuit breaker. Place the main power switch in the "OFF" position and unscrew the fuse(s) or switch "OFF" the circuit breaker switch(es) that control the power to the fixture or room that you are working on.
- Place the wall switch in the "OFF" position.

AVERTISSEMENT

IMPORTANT : Coupez l'électricité avant TOUTE manipulation.

- Lisez toutes les instructions avant d'installer.
- Système est destiné à être installé par un électricien qualifié en conformité avec le code national de l'électricité et les règlements locaux.
- Toujours mettre le fusible ou le disjoncteur en position arrêt dans la pièce ou des travaux électriques sont prévus.
- Placez l'interrupteur mural en position d'arrêt (« OFF »).

Fig.1 Installation

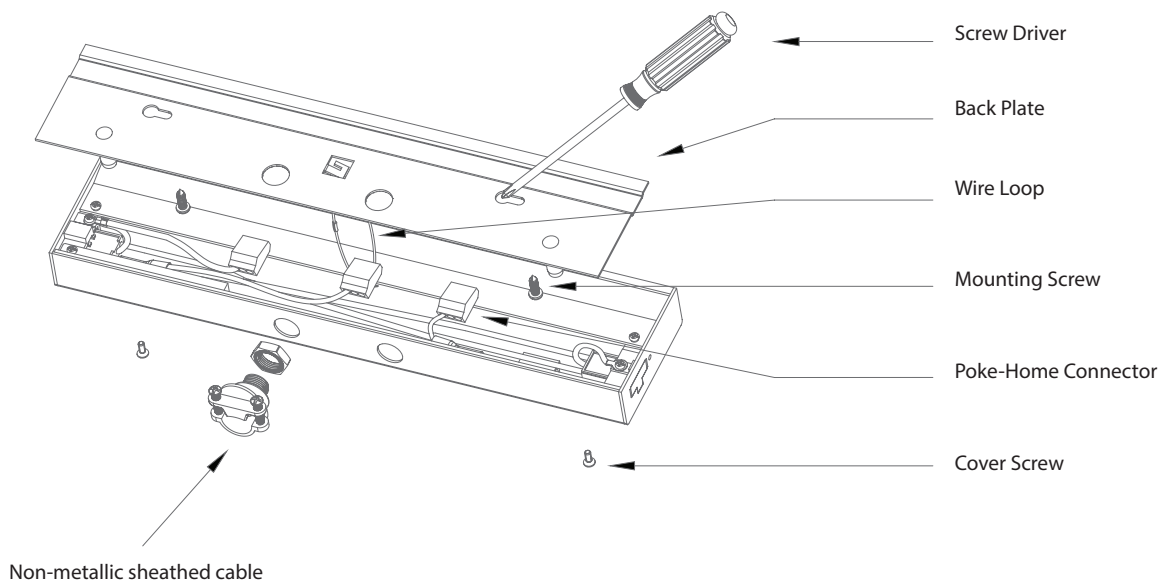

WIRING AND INSTALLATION Fig.1

1. Remove the cover screws from the face of the LED light bar and set them aside.
2. Carefully separate the back plate from the LED light bar using a screw driver.
3. Position the back plate on mounting surface and mark keyhole positions. Install the back plate using mounting screws provided.
4. Pry open the knock out holes on the long side of the fixture to install the input wires. On 12", 18", 24" and 30" models, a second knock out hole is provided to allow multiple LED light bars to be wired from a single input.
5. Install the Non-metallic sheathed cable / BX connector to the knocked out hole.
6. For ease of installation, use the wire loop to hang the fixture onto the back plate during wiring.
7. Allow approximately 2 1/2" of 120V input wires to enter the fixture body.

INSTALLATION INSTRUCTION

AC-LED LEDme® Light Bars

BA-ACLED8, BA-ACLED12, BA-ACLED18, BA-ACLED24, BA-ACLED30

WAC LIGHTING
Responsible Lighting®

- Strip 3/8" insulation off 120V input wires. Connect input wires to LED light bars using convenient "poke home" connectors provided within LED light bars. Push 120V input wires firmly into "poke home" connectors for secure connections. Fig. 2

Fig.2 Input Wire

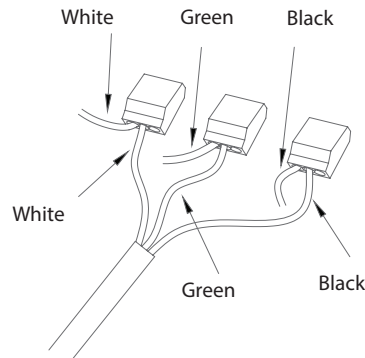

Connect black input wire to black fixture wire.
Connect white input wire to white fixture wire.
Connect green ground wire (may be bare copper) to green fixture wire.

- Tuck all the wires neatly into the LED light bar.
- Snap the back plate onto the LED light bar.
- Secure the LED light bar onto the back plate with cover screws.

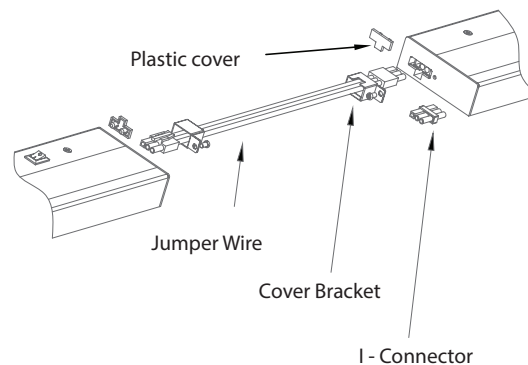

WIRING MULTIPLE UNITS:

In addition to hard wiring multiple fixtures, components are provided to allow fixtures to be linked through surface wiring.

a) End to End Connection with I-Connector (One included with each light bar) :

The I-Connector allows two fixtures to be connected end to end. I-Connector has one square and two round pins to ensure the correct orientation.

NOTE: The total number of all connected fixtures should not exceed 6 pieces for BA-I.

- Pry out the plastic covers concealing the female connection ports at the end of the fixtures.
- Install the first fixture as described above. Install the back plate for the second fixture next to the first one.
- Insert one end of the "I" connector into the first fixture. Slide the second fixture into the first one.
- Secure the position of the second fixture by using mounting screws.

b) Connection with interconnect cable (Sold Separately) :

A jumper wire allows multiple units to be linked through surface wiring.

The jumper wire has one square and two round pins to ensure the correct orientation.

NOTE: The total number of all connected fixtures should not exceed 4 pieces for BA-IC12, BA-IC24. 3 pieces for BA-IC36

- Pry out the plastic covers concealing the female connection ports at the end of the fixtures.
- Insert the ends of the connectors into each fixture.
- Jumper wires have metal strain relief cover brackets. Slide the cover bracket over the connector. Position the bracket so that the hole in the bracket aligns with the hole in the fixture. Use the screw supplied to secure the cover bracket to the fixture.
- Wrap excess wires using wire ties if necessary.