

IMPORTANT SAFETY INFORMATION

Read all instructions before installation

CAUTION - Risk of Electric Shock.

ATTENTION - RISQUE DE CHOC

READ AND FOLLOW ALL SAFETY INSTRUCTIONS

1. **DANGER-** Risk of shock- Disconnect power before installation.
DANGER – Risque de choc – Couper l'alimentation avant l'installation.
2. This luminaire must be installed in accordance with the NEC or your local electrical code. If you are not familiar with these codes and requirements, consult a qualified electrician.
Ce produit doit être installé conformément à NEC ou votre code électrique local. Si vous n'êtes pas familier avec ces codes et ces exigences, veuillez contacter un électricien qualifié.
3. Do not install insulation within 3" (76mm) of any part of the luminaire
Ne pas mettre l'isolant à moins de 76 mm (3 po) de toute partie du luminaire.
4. Access above ceiling required.
Accès requis au-dessus du plafond.
5. Do not handle energized module with wet hands or when standing on wet or damp surfaces, or in water.
6. Suitable for suspended ceilings.
7. Maximum mounting height of 10 feet.
8. Do not use this equipment for other than its intended use.
9. Do not use outdoors.

SAVE THESE INSTRUCTIONS FOR FUTURE REFERENCE

TO INSTALL

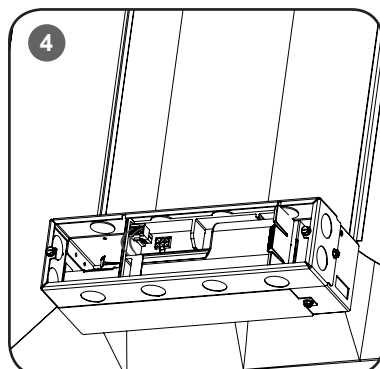
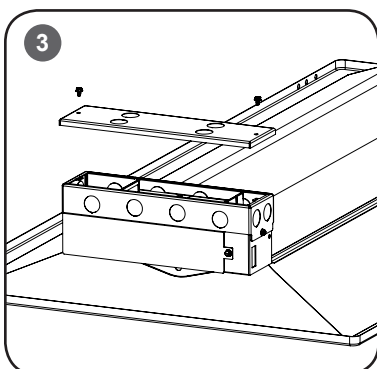
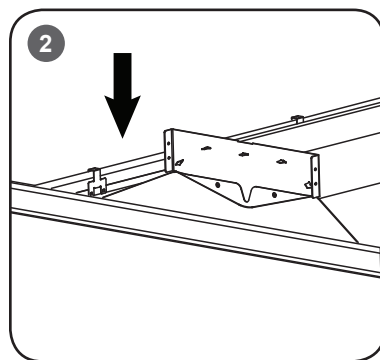
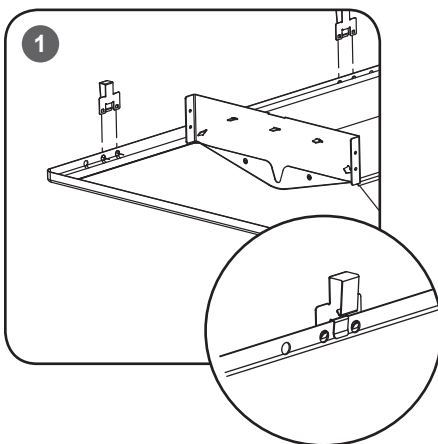

INSTALLATION INSTRUCTIONS INSTRUCTIONS D'INSTALLATION

- The CR Series is for non-insulated ceiling applications using T-Bar ceiling grid only.
- Designed for use in 120-277V 50/60 Hz protected circuits (fuse box, circuit breaker). Supply wire sized in accordance with national and local electrical wiring codes rated 90C or higher.

STEP 1:

Unpack the CR troffer from its shipping container. See **Figure 1**.

STEP 2:

Install the (4) T-Bar clips included with the luminaire (located in pre-pack fastened to luminaire J-Box).

STEP 3:

Place the CR troffer into the T-Bar Ceiling panel. Ensure T-Bar clips are attached to the T-Bar. See **Figure 2**.

STEP 4:

Remove junction box lid by removing screws to access wiring connections. Remove all packaging from the battery compartment prior to installation. Remove appropriate knockout from junction box to route input conduit. See **Figure 3**.

STEP 5:

Connect input conduit to junctions box. See **Figure 4**. Make wiring connections per the **Electrical Connection** Section on the next page.

STEP 6:

Remove the 'Notice' label covering the socket located in the battery compartment and insert plug from the battery pack into the socket. Push all wires back into the junctions box and reinstall junction box lid.

ELECTRICAL CONNECTIONS-

NOTE: The emergency driver must be fed from the same branch as the AC Driver.

STEP 1:

Using customer supplied 90°C minimum rated wire connectors, make the following electrical connections:

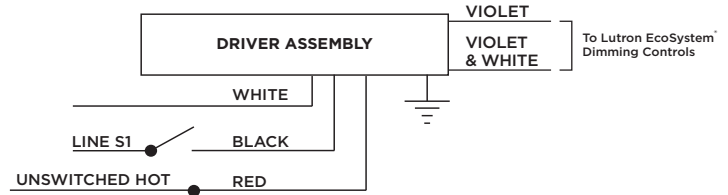

LUTRON ECOSYSTEM® DIMMING:

- Connect the black lead to Switched Hot.
- Connect the red lead to Un-switched Hot
- Connect white lead to the Neutral.
- Connect green lead to the Ground.
- Connect the violet lead to the Lutron EcoSystem® Dimming Control.
- Connect the violet/white lead to the Lutron EcoSystem® Dimming Control.

STEP DIMMING:

- Connect the black lead to Switched Hot #1 (S1).
- Connect the black lead to Switched Hot #2 (S2).
- Connect the red lead to Un-switched Hot
- Connect white lead to the Neutral.
- Connect green lead to the Ground.

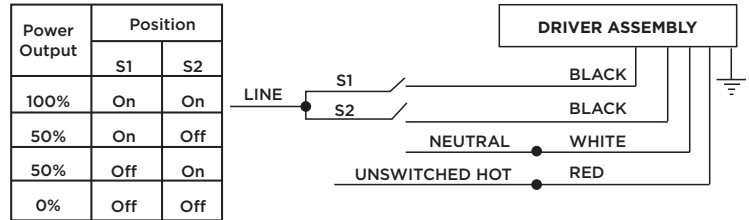

NOTE: (1) DO NOT CONNECT two separate phases of the line voltage to the input of the CR Series LED Light Engines, the LED driver will be damaged and not covered by warranty. (3) The AC line inputs must be connected to the same phase of the line voltage. (4) If step dimming isn't required, combine BLACK-Switched HOT #1 (S1) and BLACK- Switched HOT #2 (S2) together.

0-10V DIMMING:

- Connect the black lead to Switched Hot.
- Connect the red lead to Un-switched Hot
- Connect white lead to the Neutral.
- Connect green lead to the Ground.
- Connect violet lead to the supply Positive dimming.
- Connect grey lead to the supply Negative dimming.

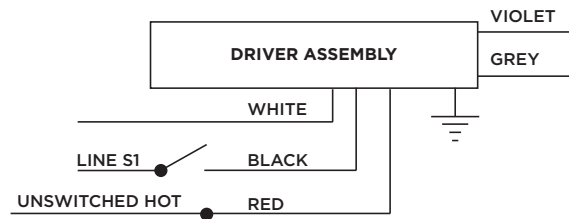

USER MANUAL:

INITIATING A BATTERY TEST

Depending on configuration, the EB14 may only enable battery testing when the battery is fully charged. If the Indicator-LED is showing a "green on solid", then the battery is fully charged. The user may initiate a battery test by either: 1) Pressing and releasing the push-button switch, or 2) Shining a bright light on the test button optical sensor. **Note: The optical sensor is co-located with the push-button switch and the Indicator-LED's.**

Battery Test Switch

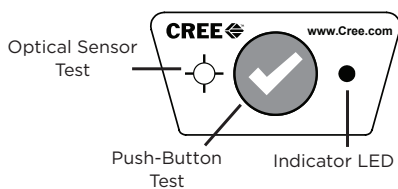

CR Series Troffer

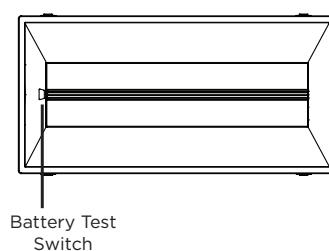

When the user presses and holds the push-button switch for less than 5 seconds, the EB14 initiates a "monthly" test of 30 seconds duration. When the user presses and holds the push-button switch for more than 5 seconds, the EB14 initiates a "yearly" test of 90 minutes duration. Similarly the user may shine a bright light onto the EB14's optical sensor to initiate the equivalent tests. For a monthly test, the user shines the light for a minimum of 1 second and maximum of 5 seconds. For an annual test, the user shines the light for

a minimum of 5 seconds. To provide feedback to the user, the EB14 momentarily flashes the Green Indicator-LED to signal initial activation (and subsequent 5-second activation) of the Button or Optical Sensor.

OBSERVING THE BATTERY TEST

To verify the proper performance of the EB14, the user observes the light and LED indicators during the battery test. After initiating the battery test, the user should observe that the light: 1) Transitions rapidly from full brightness to nearly off 2) Increases illumination gradually (over a few seconds) until it reaches the initial emergency lighting level. The initial lighting level is product-dependent, but is typically 1400 Lumens. It is not necessary for the user to observe the entire test (especially the annual test) for the entire time period; however, it is necessary for the user to observe at least part of the testing - see "Observations of Light Output during Battery Test", below. Once the test is initiated, the EB14 performs the test automatically until it either successfully completes the test or it detects an error condition.

If the EB14 successfully completes the battery test, it simply returns to normal operation. However if the EB14 uncovers a fault condition, it reports the error via its Indicator-LED's. The indicator-LED table shows the possible fault indicator sequences. The EB14 continues to display the fault indicator sequence (via the Indicator-LED's) until the user clears the fault display.

USER MANUAL (CONTINUED):

EB14 State	LED State
AC present, Battery fully charged (includes trickle charge)	GREEN ON; RED OFF
AC present, Battery charge in progress	GREEN FAST BLINK; RED OFF
AC present, Test in progress	Alternate blinking RED/GREEN
AC present, Test complete:	Battery Test Passed = back to battery charge in progress state (GREEN FAST BLINK, RED OFF) Battery Test Failure = GREEN OFF, RED FAST BLINK
AC not present, running on battery	GREEN OFF; RED SLOW BLINK
Critical Error Battery Low	GREEN OFF; RED Double BLINK
Critical Error (Other)	GREEN OFF; RED Triple BLINK
Pushbutton or Optical Sensor Stuck Low	GREEN Double BLINK; RED OFF
Minor Error (Other)	GREEN Triple BLINK; RED OFF

OBSERVATION OF LIGHT OUTPUT DURING BATTERY TEST

Maintenance staff must observe the light output during Battery Test operation, to determine if any fault symptoms are exhibited. Examples of fault conditions include:

1. Light level is incorrect (too bright or too dim) relative to desired output.
2. Lighting level increases or decreases dramatically and/or rapidly over time.
3. Light color is "off" – inconsistent with "normal" color for that light.

Maintenance staff is responsible for reporting these types of errors, and replacing the faulty equipment as necessary, since these types of faults may impact building-occupant safety during an actual emergency condition.

CANCELLING A BATTERY TEST IN PROGRESS

After initiating a battery test, the user may cancel the test in process. Once the test is underway, and after a 5-second lock-out interval, the user may cancel the test by either pressing and releasing the push-button, or shining a bright light on the optical sensor for between 1 and 5 seconds.

CLEARING THE BATTERY TEST RESULTS (IF FAILED)

To clear the display of a failed-battery-test, the user presses and releases the push-button, or shines a bright light on the optical sensor for between 1 and 5 seconds.

LED INDICATORS

For normal powered operation – i.e., when both "switched" and "un-switched" AC power sources are applied, the LED Indicators show that the system is charging or charged, and the output will be either: 1) Green Fast Blink [charging], or 2) Green On Solid [charged].

During a battery test operation, the LED-Indicators will alternate between Red On and Green On, for the length of the test. At the conclusion of a successful battery test, the LED-indicators will return to that of "normal" operation – i.e., they'll indicate that the system is charging or charged. Subsequent a failed battery test, the LED-indicator output will be Red Fast Blink. The EB14 maintains this output pattern until the user cancels the fault display. **Note: Fault indications require immediate attention to assure that the EB14 system is ready when needed.**

HANDLING FAULT CONDITIONS

The table below lists the fault conditions that the LED-Indicators may display, and what steps the user must take to assure that the EB14 is ready when needed.

IMPORTANT RECOMMENDATIONS FOR THE USER AND MAINTENANCE STAFF

Maintenance personnel need to be mindful of any unusual LED indicator pattern, and to take appropriate action when observed.

When not in emergency mode, the EB14 lights operate the same as other lights wired together on the same system. If the EB14 light is off or dim when its lighting group is on, this is indicative of a fault condition. If during non-emergency (and non-test) conditions, the EB14 light is operating differently than its non-EB14 counterparts, this may indicate a fault condition.

It is recommended that at system installation, and subsequently at routine intervals not exceeding one year, the User performs a test of the Emergency Lighting system by turning off the "Un-switched" AC power.

PRODUCT SERVICING

For fault conditions described in this User Manual that persist and do not auto-clear, the user should contact a Cree Authorized representative for information regarding product services and/or returns.

LED Indicator Pattern	User Action Required
GREEN ON; RED OFF	None
GREEN FAST BLINK; RED OFF	Monitor for 24 hours while un-switched AC Power applied to verify that system achieves fully charged state (solid Green indicator). If system doesn't achieve full-charge in 24 hour period (during which no battery discharge condition occurred, and during which the un-switched AC power was continuously applied) then proceed to Product Servicing.
Alternate blinking RED/GREEN	Confirm that a battery test had been initiated; confirm that the battery test concludes in 30 seconds (for monthly test) or 90 minutes (for annual test.)
GREEN OFF, RED FAST BLINK	Confirm that a battery test had been performed, and this is the failure indication. Proceed to Product Servicing.
GREEN OFF; RED SLOW BLINK	Confirm that the unit is running on battery – i.e., that the un-switched AC power is off. If un-switched AC power is present, proceed to Product Servicing.
RED Double BLINK	This display sequence generally indicates a problem with the EB14 battery. If the condition persists, proceed to Product Servicing.
RED Triple BLINK	This display sequence generally indicates an unspecified problem with the ELM that may prevent it from performing its emergency lighting function. If the condition persists, proceed to Product Servicing.
GREEN Double BLINK; RED OFF	Pushbutton or Optical Sensor Stuck Low
GREEN Triple BLINK; RED OFF	Minor Error (Other)