

## IMPORTANT SAFEGUARDS

When using electrical equipment, basic safety precautions should always be followed including the following:

## READ AND FOLLOW ALL SAFETY INSTRUCTIONS

1. **DANGER**- Risk of shock- Disconnect power before installation.  
**DANGER - RISQUE DE CHOC - COUPER L'ALIMENTATION AVANT L'INSTALLATION**
2. **CAUTION** – Installation and servicing should be performed by qualified personnel only. De-energize before opening.  
**ATTENTION** – *L'installation et l'entretien doivent être effectués par du personnel qualifié seulement. Mettre hors tension avant l'ouverture*
3. To reduce the risk of electric shock, disconnect both standard and emergency power supplies and converter connector of the emergency driver before servicing.  
*Pour réduire le risque de décharge électrique, vous devez déconnecter à la fois le disjoncteur divisionnaire ou les fusibles et les alimentations d'urgence avant l'entretien.*
4. Do not use outdoors.  
*Ne pas utiliser à l'extérieur.*
5. Do not let power supply cords touch hot surfaces.  
*Ne laissez pas les cordons d'alimentation toucher les surfaces chaudes.*
6. Do not mount near gas or electric heaters.  
*Ne montez PAS près des appareils de chauffage de gaz ou électriques.*
7. Use caution when servicing batteries. Battery acid can cause burns to skin and eyes. If acid is spilled on skin or eyes, flush acid with fresh water and contact a physician immediately.  
*Faites preuve de prudence lors de l'entretien des batteries. L'acide de batterie peut provoquer des brûlures de la peau et les yeux. Si l'acide est versé sur la peau ou les yeux, rincer à l'eau acide frais et contacter un médecin immédiatement.*
8. Equipment should be mounted in locations and heights where it will not readily be subjected to tampering by unauthorized personnel.  
*L'équipement doit être monté dans des endroits et à des hauteurs où il ne sera pas soumis à des altérations par des personnes non autorisées.*
9. The use of accessory equipment not recommended by the manufacturer may cause an unsafe condition.  
*L'utilisation d'accessoires non recommandés par le fabricant peut causer une situation dangereuse.*
10. Suitable for suspended ceilings.
11. Max. mounting height: 10 ft.  
*Hauteur de montage max.: 10.*
12. Access above ceiling required. Do not install insulation within 3" (76mm) of any part of the luminaire.  
*Accès requis au-dessus du plafond. Ne pas mettre l'isolant à moins de 3 po (76 mm) de toute partie du luminaire*
13. Suitable for suspended ceilings.  
*Convient aux plafonds suspendus.*
14. Do not handle energized module with wet hands or when standing on wet or damp surfaces, or in water.

## INSTALLATION INSTRUCTIONS

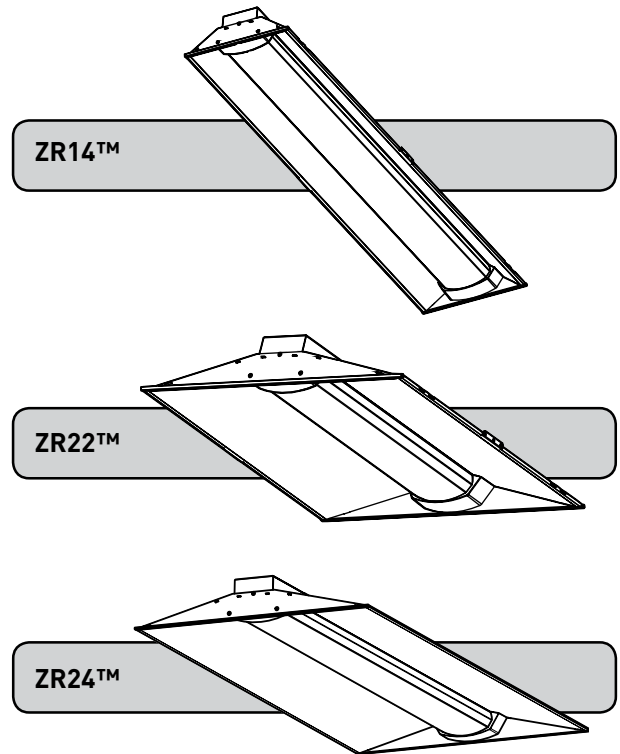

## SAVE THESE INSTRUCTIONS FOR FUTURE REFERENCE

- The ZR Series of recessed troffers is for non-insulated ceiling applications using T-Bar ceiling grid, drywall grid adaptors, and suspended mount.
- Designed for use in 120-277V 50-60 Hz or 347V 60Hz protected circuit (fuse box, circuit breaker). Supply wire sized as per NEC or governing code(s), 90C rated.
- Make sure to cap off all unused leads.
- Dimming leads shall connect only to circuitry identified as a Class 2 Circuit in accordance with the national and local Electrical Wiring Codes.

## TO INSTALL:

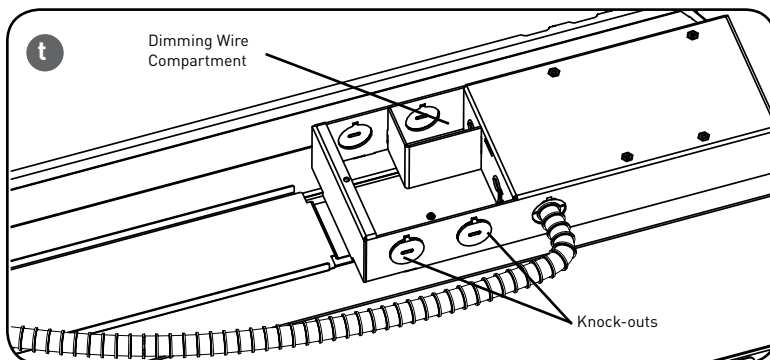
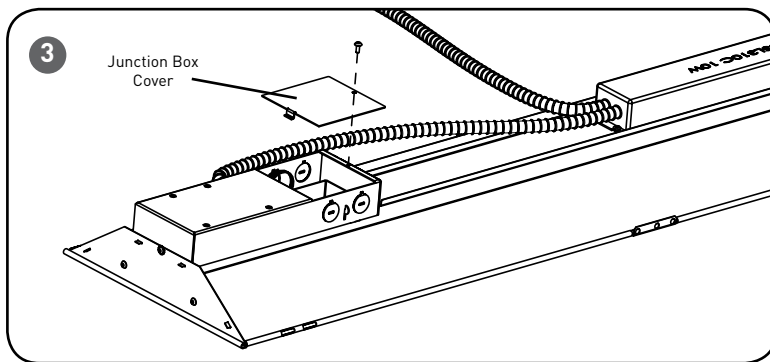
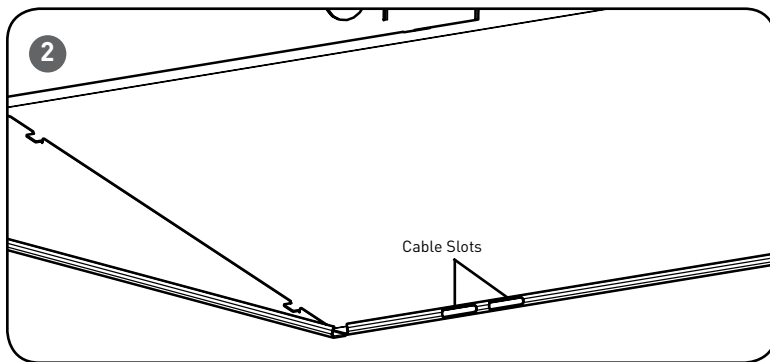
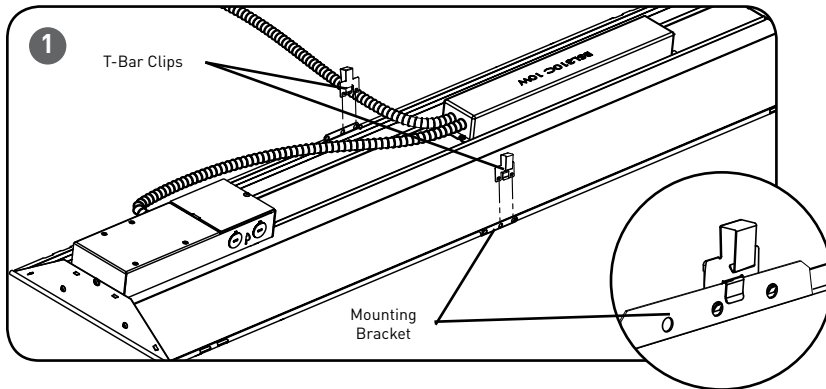

### T- BAR CEILING MOUNTING

#### STEP 1:

Install the (2) supplied T-Bar clips onto the mounting bracket on the outside of the housing. See **Figure 1**.

#### STEP 2:

Bring the ZR troffer into the T-Bar Ceiling panel and attach the clips on the housing onto the T-Bar.

### SUSPENDED MOUNTING

#### STEP 1:

Attach customer supplied cables to the (2) cable slots on each corner of the housing. See **Figure 2**.

#### STEP 2:

Attach customer supplied cables to mounting surface using customer supplied hardware. Ensuring that mounting surface can support the luminaire.

### 0 - 10V DIMMING OPTION

#### STEP 1:

Remove the cover of the junction box and bring in appropriate power supply to the junction box using one of the knock-outs. See **Figure 3 and 4**.

#### STEP 2:

Bring dimming conduit into dimming wire compartment using the knock-out. See **Figure 4**.

#### STEP 3:

Wire luminaire per "**Electrical Connections**" section and push all leads into the junction box. Reattach junction box cover that was removed in Step 1, make sure no wires are pinched.

#### STEP 4:

Install test switch assembly into ceiling by drilling a 1" hole into the ceiling.

#### STEP 5:

Unscrew the small trim ring and place test switch assembly through the ceiling. See **Figure 5**.

#### STEP 6:

Secure the test switch assembly by screwing the small trim ring removed in Step 5 back onto the test switch assembly. Tighten the larger trim ring above the ceiling until it is snugged tight against the ceiling. See **Figure 5** on page 3.

### EMERGENCY DRIVER CHECK

**NOTE:** For short-term testing of the emergency function, the battery must be charged for at least one hour. The emergency driver must be charged for at least 24 hours before conducting a long-term test.

#### STEP 1:

When AC power is applied, the charging indicator light is illuminated, indicating the battery is being charged. When power fails, the emergency driver automatically switches to emergency power, operating the LED array. When AC power is restored, the emergency driver returns to the charging mode.

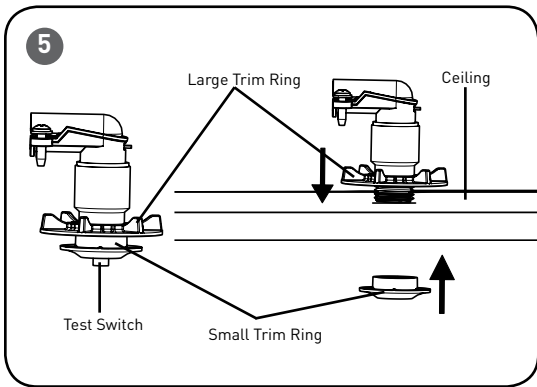

### STEP 2:

Although no routine maintenance is required to keep the emergency driver functional, it should be checked periodically to ensure that it is working. The following schedule is recommended:

- Visually inspect the charging indicator light monthly. It should be illuminated.
- Test the emergency operation of the fixture at 30-day intervals for a minimum of 30 seconds. When the test switch is depressed, the LED array should operate.
- Conduct a 90-minute discharge test once a year. The LED array should operate for at least 90 minutes.

If the luminaire fails any of these checks, consult service personnel.

REFER ANY SERVICING INDICATED BY THESE CHECKS TO QUALIFIED PERSONNEL. EMERGENCY DRIVER AND AC DRIVER MUST BE FED FROM THE SAME BRANCH CIRCUIT.

## ELECTRICAL CONNECTIONS

**NOTE:** The emergency driver must be fed from the same branch as the AC Driver.

### STEP 1:

Using customer supplied 90°C minimum rated wire connectors, make the following electrical connections:

- Connect the black luminaire lead to the unswitched voltage supply lead.
- Connect the white/red luminaire lead to the switched supply lead.
- Connect white luminaire lead to the neutral supply lead.
- Connect ground bare or green/yellow wire lead to the supply ground lead.
- If 0/1-10V Dimming is used, connect the violet lead to the supply positive dimming lead. If dimming is not being used ensure to cap off the violet lead.
- If 0/1-10V Dimming is used, connect the gray lead to the supply negative dimming lead. If dimming is not being used ensure to cap off the gray lead.

### STEP 2:

Locate the two red leads in the junction box and connect them using customer supplied connector.

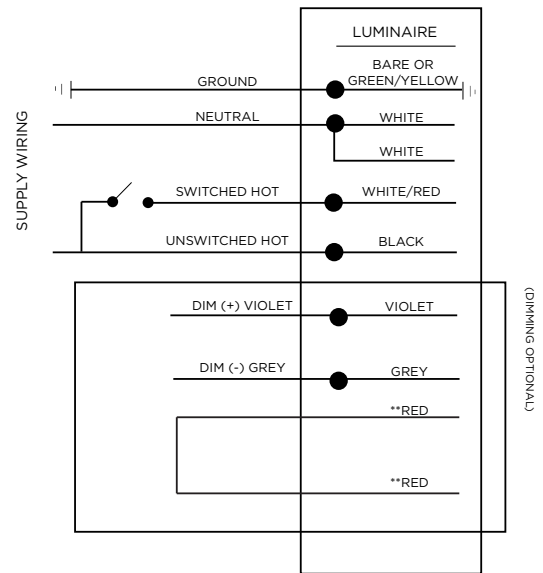

\*\* NOTE: DO NOT mate leads until installation is complete and AC power is supplied

## FCC NOTICE

**CAUTION:** Changes or modifications not expressly approved could void your authority to use this equipment.

This device complies with part 15 of the FCC Rules. Operation is subject to the following two conditions: (1) This device may not cause harmful interference, and (2) this device must accept any interference received, including interference that may cause undesired operation.

This equipment has been tested and found to comply with the limits for a Class A digital device, pursuant to part 15 of the FCC Rules. These limits are designed to provide reasonable protection against harmful interference when the equipment is operated in a commercial environment. This equipment generates, uses, and can radiate radio frequency energy and, if not installed and used in accordance with the instruction manual, may cause harmful interference to radio communications. Operation of this equipment in a residential area is likely to cause harmful interference in which case the user will be required to correct the interference at his own expense.

CAN ICES-003 (A)/NMB-003 (A)