

IMPORTANT SAFEGUARDS

When using electrical equipment, basic safety precautions should always be followed including the following:

READ AND FOLLOW ALL SAFETY INSTRUCTIONS

- DANGER**- Risk of shock- Disconnect power before installation.
DANGER – Risque de choc – Couper l'alimentation avant l'installation.
- WARNING**- Risk of fire. Use only in place of fluorescent lamps specified on label.
AVERTISSEMENT - Risque de feu. Utiliser uniquement sur place des lampes fluorescentes précisées sur l'étiquette.
- CAUTION**- Direct replacement for 25W/48T8/HF lamps only.
NOTE: Most electronic ballasts support 25W/48T8/HF, 28W/48T8/HF, 30W/48T8/HF, and 32W/48T8/HF lamps, and therefore will work with this lamp.
ATTENTION - Remplacement direct pour 25W/48T8/HF lampes uniquement.
- CAUTION** - If the lamp or luminaire exhibits undesirable operation (buzzing, flickering, etc.), Immediately turn off power, remove lamp from luminaire and contact manufacturer.
ATTENTION - Si la lampe ou luminaire présente un fonctionnement indésirable (bourdonnement, scintillement, etc), éteignez immédiatement le pouvoir, supprimer lampe luminaire et fabricant de contact.
- This lamp will only operate on T8 electronic ballasts. If lamp does not light when the luminaire is energized, remove lamp and contact lamp manufacturer or qualified electrician.
Ce témoin ne fonctionnera que des T8 ballasts électroniques. Si le témoin ne s'allume pas lorsque le luminaire est sous tension, enlever la lampe et contact lamp fabricant ou un électricien qualifié.
- This lamp employs light emitting diode technology and unlike tungsten-halogen lamps does not require a barrier. Lamp is suitable for open luminaires.

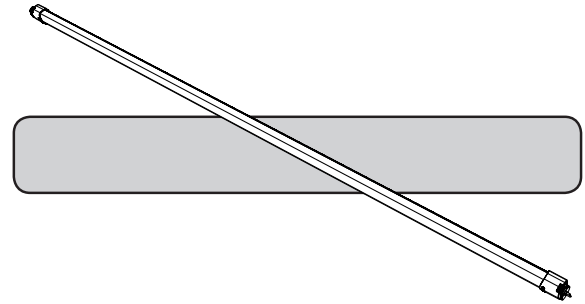

INSTALLATION INSTRUCTIONS INSTRUCTIONS D'INSTALLATION

SAVE THESE INSTRUCTIONS FOR FUTURE REFERENCE

TO INSTALL:

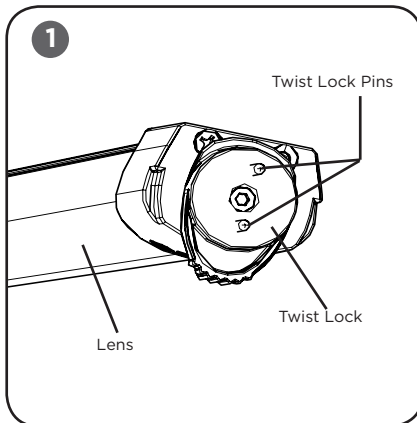

STEP 1:

Turn power off.

STEP 2:

Remove existing fluorescent lamps and verify they are 25W/48T8/HF. If yes, go to step 4. Wattage is typically located on the end of the lamp.

STEP 3:

If the lamps are marked anything other than 25W you need to verify the type of ballast installed. On the ballast it will state which lamps it supports* (25W/48T8/HF, 28W/48T8/HF, 30W/48T8/HF, or 32W/48T8/HF). If the ballast states it supports 25W lamps then go to step 4. Otherwise go to step 7.

STEP 4:

Ensure that the pins on the twist locks are in the vertical position. See **Figure 1**.

STEP 5:

Bring lamp into luminaire and insert both lamp sockets into the luminaire at the same time.

NOTE: Ensure that the lamp is installed with the lens pointing away from the base of the luminaire.

STEP 6:

Secure lamp by turning the twist lock into lock position on both ends of the lamp. Twist lock pins will be horizontal when twist lock is in locked position. See **Figure 1**.
NOTE: Figure 1 is not shown in locked position.

STEP 7:

If the ballast is not a universal wattage ballast then you will need to replace it with a ballast rated for use with 25W T8 lamps. Once replaced perform steps 4 thru 6.