

MSR Short Arc

MSR 400 SA 1CT



The lamp's short arc and compact design helps enable a compact luminaire that provides high beam intensity, while the excellent color rendition characteristics help ensure optimal colors on stage. The highly innovative P3 technology, developed by Philips, allows MSR Short Arc lamps to be used at higher temperatures in any burning position. The result? Longer lifetime, fewer early failures and a highly consistent performance throughout the lamp's lifetime.

Product data

• General Characteristics

System Description	Short Arc
Cap-Base	GY9.5
Cap-Base Information	-
Execution	-
Operating Position	any
Main Application	Studio/Disco
Life to 50% failures	750 hr
EM	

• Light Technical Characteristics

Color Code	-
Color Rendering Index	75 Ra8
Color Temperature	5600 K
Color Temperature Technical	5662 K
Chromaticity Coordinate X	330 -
Chromaticity Coordinate Y	342 -
Luminous Flux Lamp EM	23500 (min), 30000 (nom) Lm
Luminous Efficacy Lamp EM	75 Lm/W

• Electrical Characteristics

Watts	400 W
Lamp Wattage Technical	400 W

Lamp Current	8.4 A
Ignition Supply Voltage	207 (min) V
Dimmable	No

• Luminaire Design Requirements

Pinch Temperature	500 (max) C
Bulb Temperature	1000 (max) C

• Product Dimensions

Overall Length C	80 (max) mm
Diameter D	23.5 (max) mm
Light Center Length L	36 (min), 36.5 (nom), 37 (max) mm
Arc Length O	3.0 mm

• Product Data

Product number	245001
Full product name	MSR 400 SA 1CT
Short product name	MSR 400 SA 1CT/40
Pieces per Sku	1
eop_pck_cfg	40
Skus/Case	40
Bar code on pack	8727900924213
Bar code on case	8727900924220
Logistics code(s)	928170205114
eop_net_weight_pp	0.019 kg



PHILIPS

sense and simplicity

Dimensional drawing

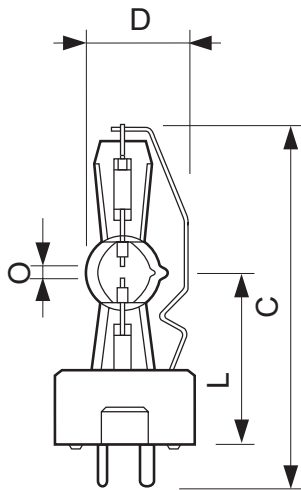

GY9.5

Product	A (Min)	A (Norm)	A (Max)	C (Max)	D (Max)	D1 (Norm)	F (Min)	F (Norm)	F (Max)	L (Min)	L (Norm)	L (Max)	O (Norm)
MSR 400 SA	-	-	-	80	23.5	-	-	-	-	36	36.5	37	3.0

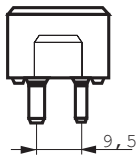
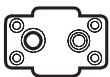

GY9.5

Photometric data

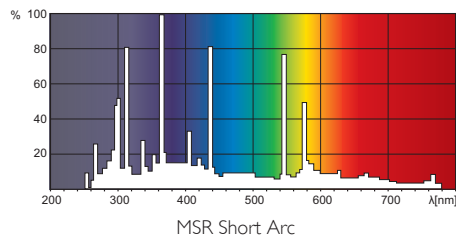
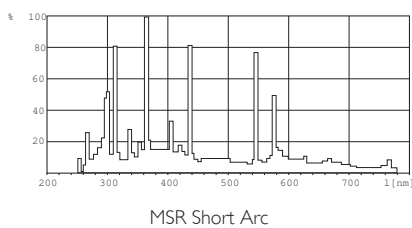

© 2012 Koninklijke Philips Electronics N.V.
All rights reserved.

Specifications are subject to change without notice. Trademarks are the property of Koninklijke Philips Electronics N.V. or their respective owners.

www.philips.com/lighting

2012, April 13
data subject to change