



PAR38

Benefits

- Higher efficacy offers more light output while consuming less power.
- Only 16W/19W - Requires 80% less power than comparable 90/120W incandescent lamps.
- Dimmable to 10% on most dimmers
- Four available color temperatures and two available beam angles offer a multitude of combinations to fit almost any need or application.
- Suitable for wet locations.
- Maintenance free operation, lasts up to 40 longer than Incandescent lighting.
- RoHS Compliant - Contains no Mercury or Lead.

FEATURES¹

Equivalent Source Standard	90W & 120W Incandescent
Rated Life	40,000 hours
Housing	Aluminum
Socket	E26
Beam Spread	40°, 25°
Flood, Narrow Flood	
Operating Temperature	-20°C to +40°C
E26 MOL	5.08in, 129.03mm
Voltage	120VAC
Weight	1lbs., 453.59g
Power Factor	≥.9
Warranty	5 year limited

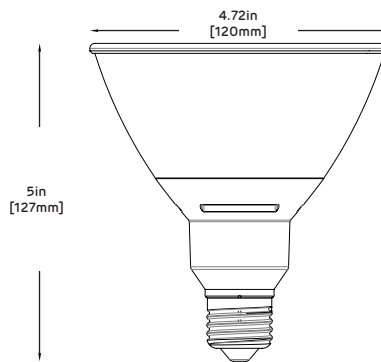

Specifications supplied are nominal. Please refer to the DOE's Lighting Facts Tolerance Guidelines.
¹ Values are nominal, advances from further innovation, specifications are subject to change.

ORDERING INFORMATION \ \ LS 38 90WE WW FL 120 S1 BX

Family	Product	Watt Equivalent	Color (CCT)	Distribution	Voltage	Family	Packaging
LS Lighting Science	38 PAR38	90WE 90W Equivalent	W27 Soft White 2700K	FL Flood	120 120 Volt	S1	BX Box
		120WE 120W Equivalent	WW Warm White 3000K	NFL Narrow Flood			
			NW Neutral White 4000K				
			CW Cool White 5000K				

NORTH AMERICAN CERTIFICATIONS



ENVIRONMENT



PAR38

DIMMER CAPABILITIES¹ 90WE

Lutron

C*L Wall Mount : Diva/Skylark/
Skylark Contour/Ariandi/Toggler/
Lumea

RadioRA2 : RRD-10ND, RRD-6NA

Maestro Wireless : MRF2-6ND

Homeworks QS : HQRD-6ND,
HQRD-10ND, HQRD-6NA, HxD-6ND

Stanza : SZ-6ND

Panel Modules : HW/LP-RPM-
4A-120, HW/LP-RPM-4U-120, GP
(Harrier) Card,

Grafik Eye : Grafik Eye QS Main
Unit Family, Grafik Eye 3000
Family

120WE

Lutron

C*L Wall Mount : Diva/Skylark/
Skylark Contour/Ariadni/Toggler/
Lumea

Panel Modules : HW/LP-RPM-
4A-120, HW/LP-RPM-4U-120, GP
(Harrier) Card,

Grafik Eye : Grafik Eye QS Main
Unit Family, Grafik Eye 3000
Family

PAR38

Part Number	Base Type	Wattage	Beam Angle	Lumens	Voltage	Efficacy	CRI	CBCP
LS 38 90WE W27 NFL 120 S1 BX	E26	16	25	960	120	60	80	3697
LS 38 90WE WW NFL 120 S1 BX	E26	16	25	960	120	60	80	3697
LS 38 90WE NW NFL 120 S1 BX	E26	16	25	1020	120	64	80	3697
LS 38 90WE CW NFL 120 S1 BX	E26	16	25	1000	120	63	80	3697
LS 38 90WE W27 FL 120 S1 BX	E26	16	40	950	120	59	80	1533
LS 38 90WE WW FL 120 S1 BX	E26	16	40	1000	120	63	80	1533
LS 38 90WE NW FL 120 S1 BX	E26	16	40	1020	120	64	80	1533
LS 38 90WE CW FL 120 S1 BX	E26	16	40	1100	120	69	80	1533
LS 38 120WE W27 NFL 120 S1 BX	E26	19	25	1200	120	63	80	5382
LS 38 120WE WW NFL 120 S1 BX	E26	19	25	1250	120	66	80	5382
LS 38 120WE NW NFL 120 S1 BX	E26	19	25	1150	120	61	80	5382
LS 38 120WE CW NFL 120 S1 BX	E26	19	25	1180	120	62	80	5382
LS 38 120WE W27 FL 120 S1 BX	E26	19	40	1200	120	63	80	2231
LS 38 120WE WW FL 120 S1 BX	E26	19	40	1200	120	63	80	2231
LS 38 120WE NW FL 120 S1 BX	E26	19	40	1150	120	61	80	2231
LS 38 120WE CW FL 120 S1 BX	E26	19	40	1300	120	68	80	2231

NFL: Narrow Flood FL: Flood NW: Neutral White WW: Warm White W27: Soft White 2700K CW: Cool White
CBCP: Center Beam Candle Power

Recommended number of lamps per 600 watt dimmer²

While an LED lamp may draw as few as 10 watts continuously, it could have an in-rush current spike (maximum, instantaneous input) which may limit the number of lamps you can install on one dimmer. The following table provides a recommended maximum quantity of LS lamps that should be used on a typical approved 600W dimmer.

Ex: Max number of A19 60W lamps, with an 80W in-rush, that can be used on 600W dimmer = 7

LS LED Lamp	Lamp In-Rush Current Equivalent	Max # of Lamps per 600W Dimmer
PAR38 90WE	46W	13
PAR38 120WE	32W	18

Specifications supplied are nominal. Please refer to the DOE's Lighting Facts Tolerance Guidelines.

¹ Dimmer compatibility list indicates those dimmers that have been tested and operate properly under normal conditions. In certain cases, approved dimmers are offered in higher wattage varieties that are also compliant and allow the installation of additional lamps if kept within the maximum inrush current equivalent provided in the table. Each application is unique and various factors such as load, common neutrals or other electrical products on the circuit can, in certain instances, cause variance in system performance. Consult dim5ing system manufacturer for additional support in operation.

² Values are nominal, advances from further innovation, specifications are subject to change.



Visit www.lsgc.com/energystar for list of ENERGY STAR qualified lamps.



CAUTIONS

THIS DEVICE IS NOT INTENDED FOR USE WITH EMERGENCY EXITS. NOT FOR USE IN TOTALLY ENCLOSED FIXTURES. CAUTION: RISK OF SHOCK - DO NOT USE WHERE DIRECTLY EXPOSED TO WATER, TURN OFF POWER BEFORE INSPECTION, INSTALLATION, OR REMOVAL. DO NOT OPEN - NO USER SERVICEABLE PARTS INSIDE. Suitable for wet locations. Use only on 120 volt, 60 Hz circuits. This device complies with part 15 of the FCC rules and has been tested and found to comply with the limits for a class B digital device. This Class B digital apparatus complies with Canadian ICES-003. These limits are designed to provide reasonable protection against harmful interference in a residential installation. This equipment generates, uses and can radiate radio frequency energy and, if not installed and used in accordance with the instructions, may cause harmful interference to radio communications. Any changes or modifications not expressly approved by the manufacturer could void the user's authority to operate the equipment. For use with light dimmers. Compatible with most dimmer switches. For complete details on our warranty and dimmer compatibility, please visit www.lsgc.com/warranties and www.lsgc.com/dimmer.

Specifications are typical values and may change without notification.
©2014 Lighting Science Group Corporation. All rights reserved.