



IIS-125

125W UNIT INVERTER EQUIPMENT

INSTRUCTION MANUAL

IMPORTANT SAFEGUARDS

When using electrical equipment, basic safety precautions should always be followed, including the following:

READ AND FOLLOW ALL SAFETY INSTRUCTIONS

1. **DO NOT USE OUTDOORS.**
2. Do not mount near gas or electric heaters.
3. Do not use this equipment for other than its intended use.
4. The **IIS-125** should be mounted securely and in locations and at heights where it will not readily be subjected to tampering by unauthorized personnel.
5. The **IIS-125** is not for use in air supply/air return ceilings.
6. The use of accessory equipment and replacement parts not recommended by IOTA Engineering, LLC may cause an unsafe condition and void the warranty.
7. The AC voltage rating of this equipment is specified on the product label. Do not connect the **IIS-125** equipment to any other voltage.
8. Use only the battery part number specified for use with the **IIS-125**. Failure to do so may cause an unsafe condition, will void warranty, and result in non-compliance with UL specifications.
9. The **IIS-125** uses sealed valve regulated lead acid batteries. Batteries can be punctured if not handled properly, therefore use caution when servicing batteries. In the event battery acid comes in contact with eyes or skin, flush with fresh water and consult a physician immediately.
10. Install in accordance with the National Electrical Code and local regulations.
11. Installation and servicing should be performed by qualified personnel.
12. Electricians and end-users need to ensure product system compatibility before final installation.

SAVE THESE INSTRUCTIONS

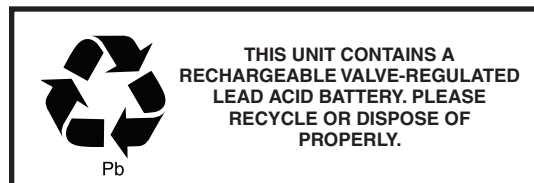

INSTALLATION INSTRUCTIONS

CAUTION: Before installing, make certain the A.C. power is off.

NOTE: The batteries are shipped separately. Place them in a location away from the work area to avoid damage until they are to be installed.

Mounting the IIS-125

Recessed Tee Bar Ceiling Mount (IIS-125-CG)

ATTENTION: The IIS-125 is not for use in air supply/air return ceilings.

- 1) Remove the side cover from the **IIS-125-CG**.
- 2) Remove the ceiling tile in the desired installation location.
- 3) Extend the unswitched, properly-rated voltage AC supply and remote fixture wires to the installation area.
- 4) Place the **IIS-125-CG** across the 2' T-bars of the ceiling grid. Support the unit with wires attached to the building steel framing. Holes are provided at the top of the **IIS-125-CG** for support wire connection. **NOTE: Do not rely on the inverted T-bar structure to support the unit.**
- 5) Connect the conduit containing the AC supply and remote fixture leads to the **IIS-125-CG**. Use the provided knock-outs on the **IIS-125-CG** for connecting the incoming wires.
- 6) Remove the battery retaining bracket and install the batteries at this time, but do not connect the battery leads until other wiring is completed. Reinstall the battery bracket. **NOTE: The batteries MUST be secured in the IIS-125-CG. Do not leave the batteries loose or unsecured within the unit.**
- 7) Use the wiring instructions on page 3 to complete connections within the **IIS-125-CG**.
- 8) After installation is complete, replace properly-sized tile into the ceiling grid. The tile should rest on the flange of the **IIS-125-CG**.

Surface Wall Mount (IIS-125-SM)

- 1) Remove the front cover of the **IIS-125-SM** by removing the two screws at the top of the cover.
- 2) Extend the unswitched, properly-rated voltage AC supply and remote fixture wires to the installation area. If a recessed junction box is to be mounted in the wall behind the unit, make sure that the unswitched AC supply and any remote fixture leads have been extended to the junction box prior to mounting the **IIS-125-SM** and that there is at least 12" of exposed leads for wiring in the unit.
- 3) Knock out the (2) keyhole slots at the rear of the unit and mount the **IIS-125-SM** securely to the wall. **The IIS-125 must be mounted securely.** The keyhole slots are spaced to allow mounting to the wall's unistrut or studs.
- 4) Connect the conduit containing the AC supply and remote fixture leads to the **IIS-125-SM**. Use the provided knock-outs on the **IIS-125-SM** for connecting the incoming wires.
- 5) Remove the battery retaining bracket and install the batteries at this time, but do not connect the battery leads until other wiring is completed. Reinstall the bracket **NOTE: The batteries MUST be secured in the IIS-125-SM. Do not leave the batteries loose or unsecured within the unit.**
- 6) Use the wiring instructions on page 3 to complete connections within the **IIS-125-SM**.

Wiring

1. CONNECTING THE INVERTER AC INPUT (FIGURE 1)

The Inverter AC Input leads (designated "Input Leads") serve as your normal power sense and charging input for the internal battery, therefore the **IIS-125** requires an unswitched AC input of either 120 or 277 VAC. If a local switch is present on the designated emergency circuit, the **IIS-125** input must be wired ahead of the switch.

- A. **For 120V** supply, connect the AC line wire to the BLACK lead coming from the inverter housing labeled INPUT WIRES. **For 277V** supply, connect the AC line wire to the ORANGE lead coming from the inverter housing labeled INPUT WIRES. **CAUTION: Cap the unused BLACK or ORANGE input wire. Failure to do so may result in equipment failure and void the warranty.**
- B. Connect the Neutral wire to the WHITE lead labeled INPUT.
- C. Connect the ground wire in accordance with local and national codes. A GREEN wire is provided for this purpose. **DO NOT ENERGIZE THE CIRCUIT AT THIS TIME.**

FIGURE 1 - IIS-125 WIRING CONNECTIONS

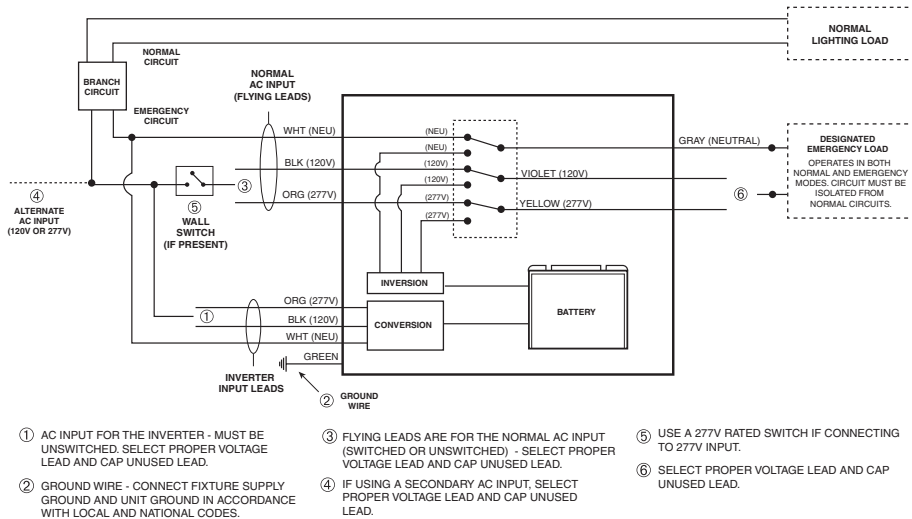

2. CONNECTING THE NORMAL AC INPUT (FIGURE 1)

The Normal AC input leads (designated “Flying Leads”) provide normal power to the designated emergency circuit. If the designated circuit is for Normally-Off fixtures (ie. emergency operation only - come on only during power failure), the Normal AC input leads are not required and should be capped separately.

A. NORMALLY-ON FIXTURES - Select the proper voltage “flying lead” (BLACK for 120V, ORANGE for 277V) and connect to the unswitched AC input. Cap the unused lead. Connect the Neutral (WHITE) “flying lead” to the unswitched AC input neutral of the supply line feeding the input wires. Refer to **Figure 1**.

B. FIXTURES ON LOCAL SWITCH (fixtures may be turned on and off locally, but will come on during power failure regardless of switch position) - Connect the load side of the switch to the proper voltage “flying lead” from (BLACK for 120V, ORANGE for 277V). Cap the unused lead. Ensure the the Inverter AC Input (“Input Leads”) are connected ahead of the local switch. Refer to **Figure 1**.

3. CONNECTING EMERGENCY FIXTURES (FIGURE 1)

A. Connect emergency fixtures to the correct output leads. The color code is as follows: neutral is Grey, 120V is Violet, and 277V is Yellow. All remote circuitry is to be wired in accordance with Article 700 of the National Electric Code. Do not exceed the total rating of the **IIS-125**. **When making connections to the IIS-125, DO NOT connect the Input Neutral (WHITE) to the Output Neutral (GRAY).**

B Connect the Fixture Supply Ground to the **IIS-125** Ground.

DO NOT ENERGIZE THE CIRCUIT AT THIS TIME.

Consult the **IIS-125 Application Notes** for connecting the unit to specific lighting loads. Application Notes are available on the internet or through Customer Service.

4. INSTALLING THE BATTERY

Use only battery part number **F741250003** with the unit. *See Page 1 of this instruction manual.*

A. Retaining brackets are provided. **The batteries MUST be secured in the IIS-125. Do not leave the batteries loose or unsecured within the unit.**

B. Connect the batteries by plugging the connector into the receptacle on the PCB. If the batteries are not provided with a connector, the PCB is equipped with Red and Black wires with ring terminals. Wire the Red wires to the Positive terminals and the Black wires to the Negative terminals. Torque hardware to 33 in/lbs.

Failure to connect or secure the batteries properly will result in equipment failure, an unsafe condition, and will void the warranty.

NOTE: The emergency indicator lights will not illuminate at this time.

5. COMPLETING INSTALLATION

- A. Energize the AC supply. The Ready (Yellow) Indicator and the Charging (Red) Indicator will illuminate. The Inverter On (Green) Indicator will not illuminate at this time.
- B. Operate the Test Switch for approximately 10 seconds. Observe that any emergency fixtures do not go out, that the Inverter On (Green) Indicator comes on, and that any normally off fixtures come on.
- C. Release the Test Switch. Normally Off fixtures and the Inverter On (Green) Indicator will extinguish. Normally On, emergency, and any switched fixtures will return to their normal operating mode.
- D. Reinstall the front cover using all the original hardware.
- E. Affix red "EMERGENCY CIRCUIT" label (provided) to the panelboard dead front cover near the circuit breaker feeding the **IIS-125**.

Operation

Normal Mode - AC power is present and operates the fixtures as intended. The **IIS-125** is in the standby charging mode. The Ready (Yellow) Indicator and Charging (Red) Indicator will be lit providing a visual indication that the unit is charging.

Emergency Mode - The AC power fails. The **IIS-125** senses the AC power failure and automatically switches to the *Emergency Mode*. All fixtures, including Normally Off or switched off fixtures, connected to the **IIS-125** will be illuminated for the duration required by national safety codes (minimum 90 minutes in US, minimum 30 minutes in Canada). When the AC power is restored, the **IIS-125** switches the system back to the *Normal Mode* and resumes battery charging. See page 1 of the instruction manual.

Testing

- 1) To test the equipment, depress the test switch. The Ready (Yellow) Indicator will go off. The designated fixtures will either illuminate if they were off or will stay on if they were normally illuminated. The Inverter On (Green) Indicator will come on.
- 2) Release the Test Switch. The Ready (Yellow) Indicator will come on. Normally Off emergency fixtures will extinguish.

The equipment is supplied with an automatic solid state charger designed to fully recharge the batteries within 48 hours after AC power is restored, and then maintain the batteries in a fully charged state. Allow the batteries to charge for a minimum of 48 hours after installation or power failure before conducting a prolonged discharge test. Monthly and annual testing should be performed in accordance with NFPA 101, local, state or municipal code requirements.

"Written records of testing shall be kept by the owner for inspection by the authority having jurisdiction."

Maintenance

- 1) **CAUTION:** Always turn off the AC supply to the equipment, and disconnect the battery before servicing. Only qualified service technicians should service this equipment. The use of parts supplied by other than IOTA Engineering, LLC may result in an unsafe condition, equipment failure and will void the warranty.
- 2) **BATTERY** - The battery supplied in this equipment is a high quality maintenance-free Valve Regulated Lead Acid design. It requires no maintenance and when installed in an ambient temperature of 20°-30° C (68°-86° F) its life expectancy is 8 to 10 years. However, as stated above, the equipment must be tested for 90 minutes a minimum of once per year. When the battery will no longer operate the load for 90 minutes it must be replaced. Replace only with IOTA Engineering, LLC supplied parts. Dispose or recycle the lead-acid battery properly.

CONTACT CUSTOMER SERVICE FOR REPLACEMENT PARTS.

SERVICING SHOULD BE PERFORMED BY QUALIFIED PERSONNEL.
Consult Customer Service for current warranty information.