

TECHNOLOGY

GaN on GaN

Quality of Light

Breakthrough Design

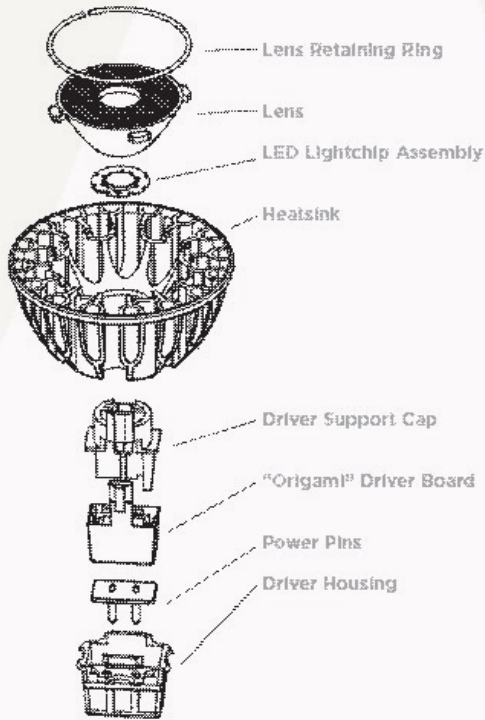

SORAA LED MR16 LAMP DESIGN

Soraa is unique among LED lamp manufacturers in designing and producing all key lamp components directly- LED dies, optics, heatsink, drivers, and other parts. Our LED lightchips are manufactured in our plant in Fremont, California. Phosphor packaging and lamp assembly are done in Asia. The carefully integrated design of the Soraa Lamp, organized around a single very small, very bright LED light source combined with a single optic and heatsink, is enabled by the unique properties and capabilities of GaN on GaN™ native substrate LED technology and features many LED industry "firsts":

- Organic branching fin geometry with a tiny core and more fins at the edge maximizes thermal transfer efficiency
- "Origami" driver circuit, designed with electronic components used in automotive and other extreme temperature environments, enables very high power densities and highly efficient thermal dissipation
- Direct attachment of LED to heatsink without intermediate PCBs increases the lamp's power densities and lowers production cost
- An LED MR16 lamp that produces 50-watt halogen equivalent light output and runs at lamp temperatures of up to 120°C, a requirement for reliable operation in the most constrained fixtures

Read [Press Release](#) on Red Dot Design Award



reddot design award
winner 2013