



Precision Lighting & Transformer

INSTALLATION INSTRUCTIONS FOR H.I.D. CORE & COIL BALLAST REPLACEMENT KITS

WARNING: The ballast and fixture must be installed and wired in accordance with the National Electrical Code, all applicable Federal, State and local electrical codes as well as the specific U.L. or C.S.A. safety standards for the intended location/application.

CAUTION: These instructions are for use as a guideline only. Installation may vary for different fixtures/applications. Be sure to follow all applicable codes listed when installing replacement kit. Installation should be performed by qualified personnel only.

Step by step installation guideline:

1. **CAUTION:** Always disconnect power to fixture before servicing or replacing components.

2. Check that new replacement ballast kit is correct for the lamp type and input voltage at the existing location.

3. **Check to be sure that power is OFF;** remove the existing ballast and capacitor. Also remove the ignitor (starter) if used.

4. Install ballast per one of the **mounting methods** listed below.

a) **Mount through the holes in the ballast core.** If new holes are needed in the fixture, please use the templates provided for appropriate ballast type.

b) **Mount ballast with "existing" removable brackets from the ballast being replaced.** Remove brackets from existing ballast being replaced. Mount these brackets to the new ballast and attach them securely by utilizing the existing fixture hardware.

c) **Mount ballast with "new brackets" supplied in the replacement kit** (Refer to mounting bracket dimensions shown). Mount brackets securely to the new ballast with hardware supplied.

5. Mount the new capacitor(s) with existing capacitor bracket or strap (where required).

NOTE: BE SURE to allow at least 5/8" clearance between the capacitor terminals and any surface to allow for oil-filled capacitor expansion.

(This expansion may occur as a result of an internal short in oil-filled metal can type capacitors). Dry-type capacitors do not need this clearance for expansion.

6. Install ignitor (starter) if required.

WARNING: To prevent overheating, the new capacitor(s) and ignitor must be installed in the same location the original capacitor(s) and ignitor were located in the existing lighting fixture. Be sure to adhere to the 5/8" clearance between the capacitor and any surface.

7. Ground all ballast system components

CAUTION: GROUND Ballast/fixture/components in compliance with National Electrical Code and all applicable Federal, State and local electrical codes

8. Connect ballast, capacitor and ignitor (if required) per the wiring diagram provided on the new replacement ballast.

CAUTION: BE SURE TO INSULATE ("CAP OFF") ANY UNUSED LEADS INDIVIDUALLY.

9. Before closing and re-energizing the fixture: Be sure to re-check all components for proper lamp type, correct wiring and secure mounting.

10. Ensure that all wiring, component installation and safety requirements have been completed, then **TURN ON POWER TO FIXTURE.**

BALLAST MOUNTING TEMPLATES

for proper alignment in fixture

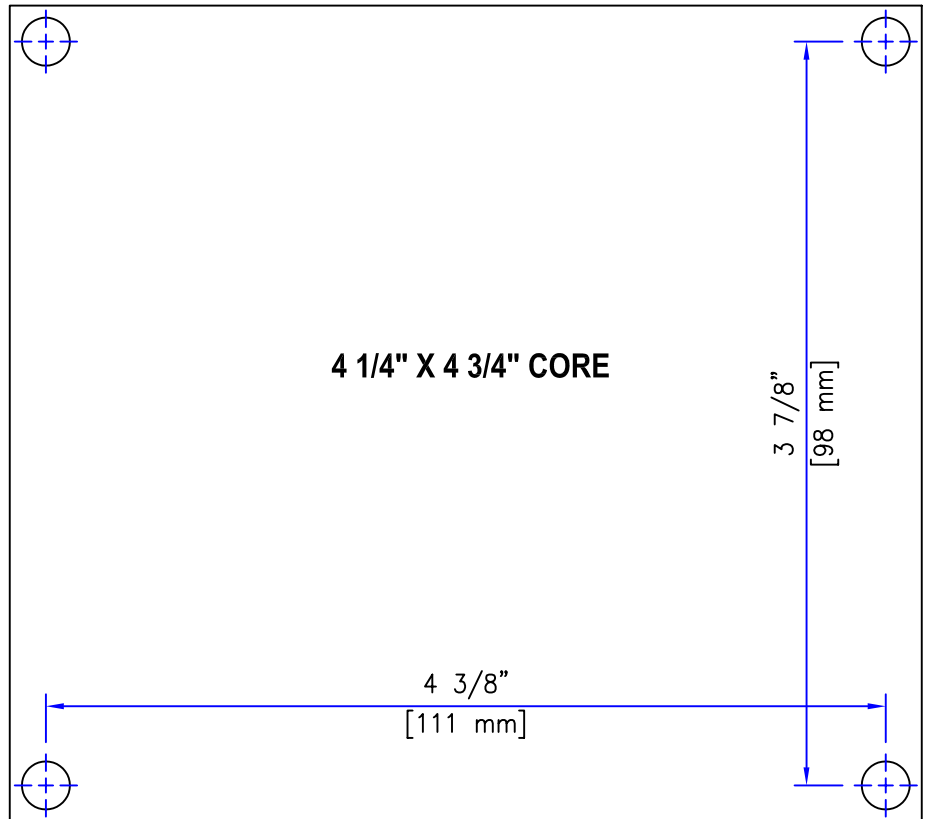
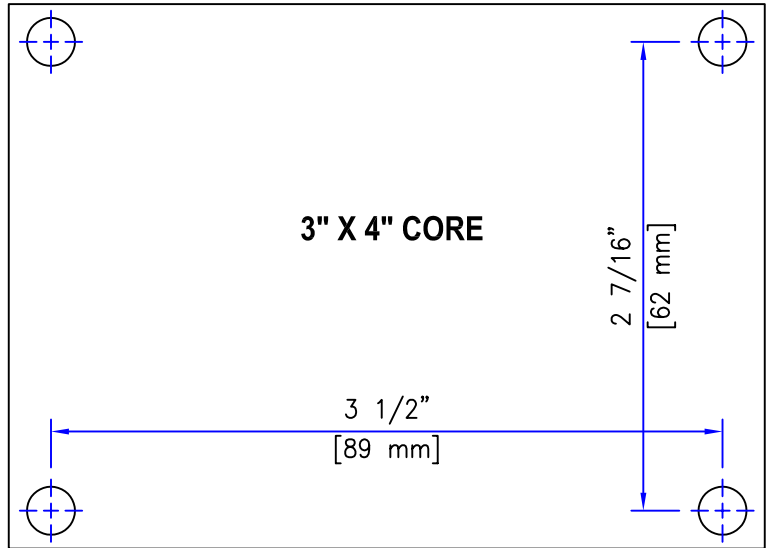
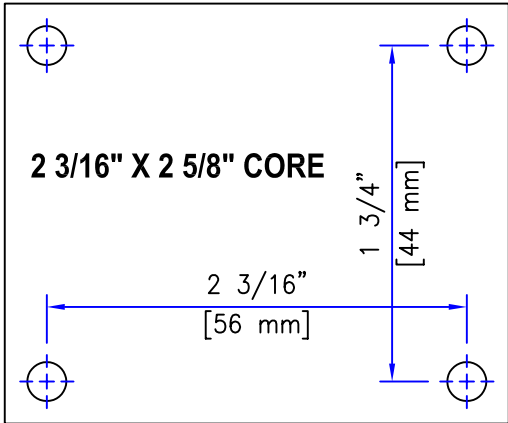

DO NOT REPRODUCE THESE TEMPLATES IN ANY WAY THAT MAY ALTER THE DRAWING SCALE (1" = 1") USED IN THE CORE ALIGNMENT DRAWINGS

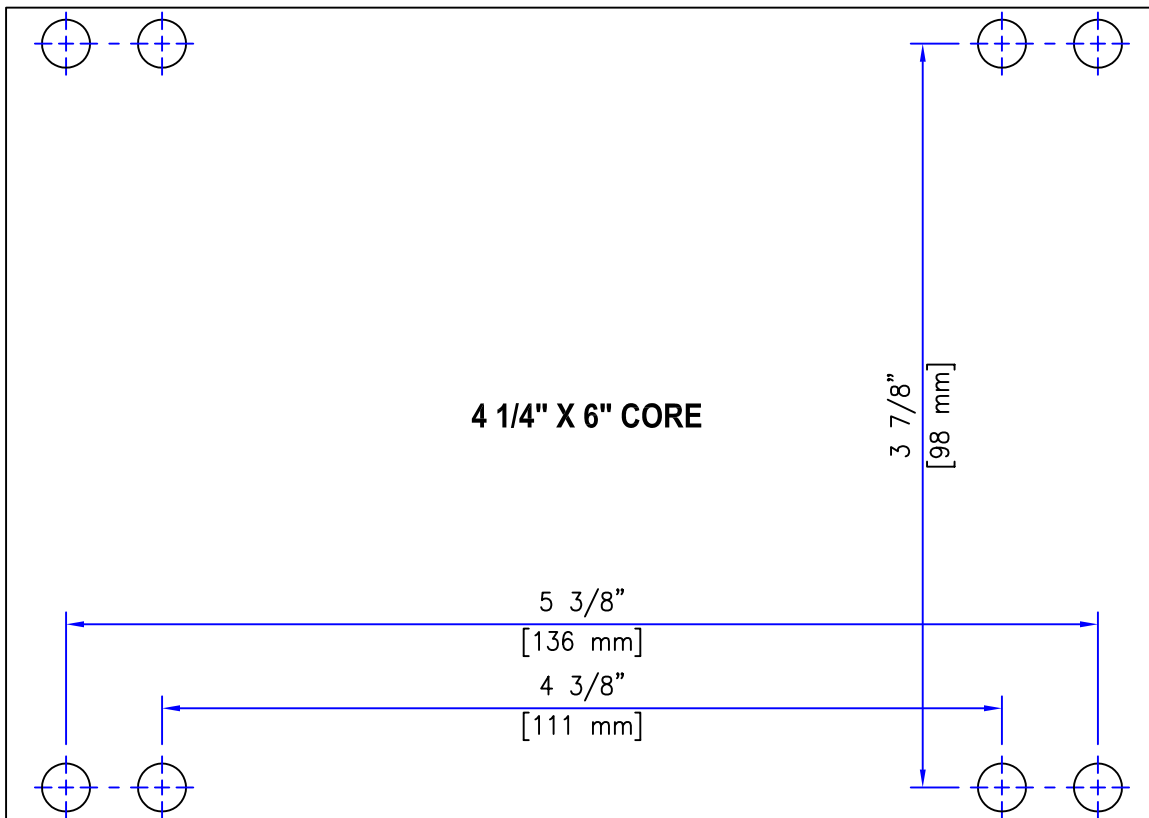
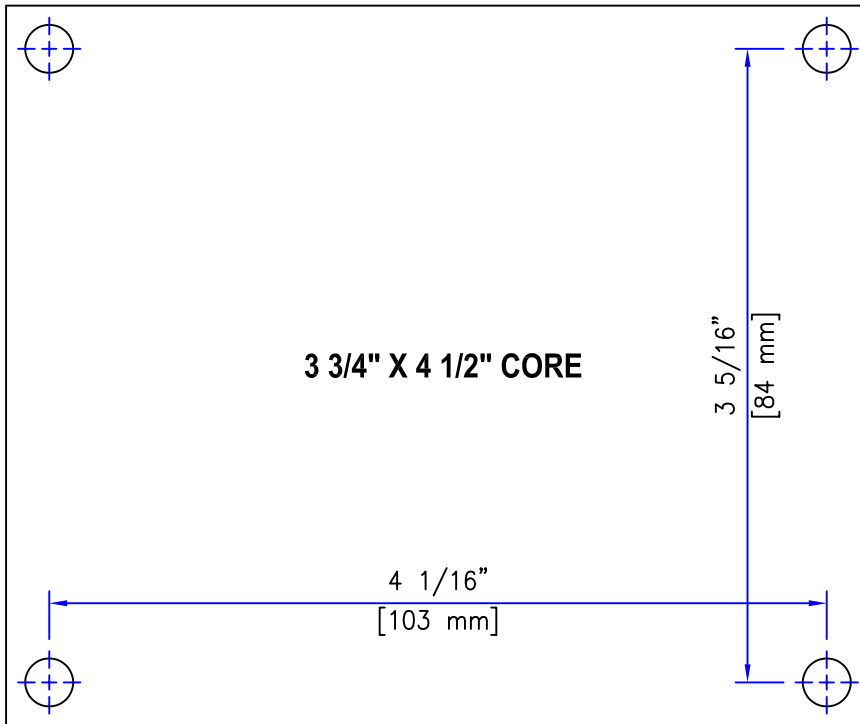



Precision
Lighting & Transformer

Mounting Bracket Dimensions

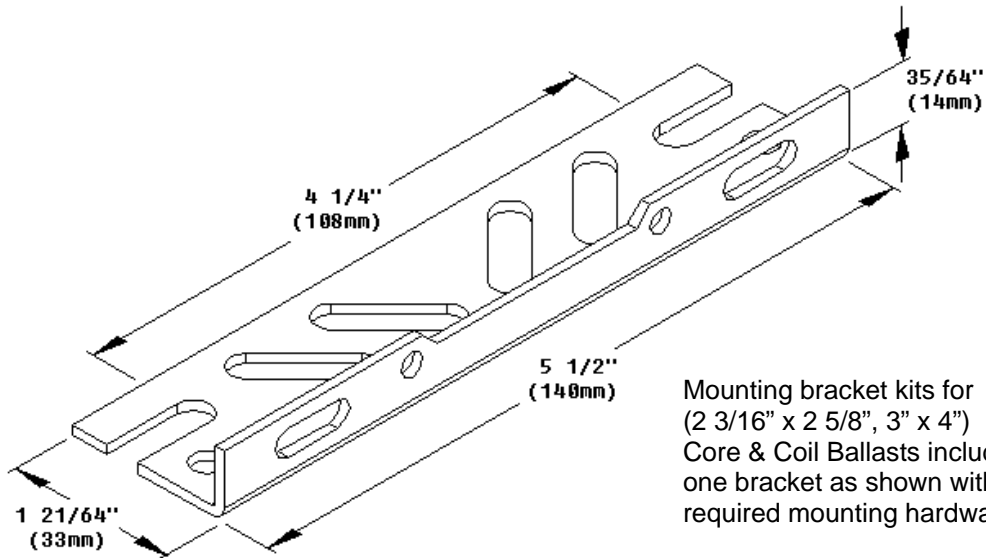

Mounting bracket kits for
(2 3/16" x 2 5/8", 3" x 4")
Core & Coil Ballasts include
one bracket as shown with
required mounting hardware

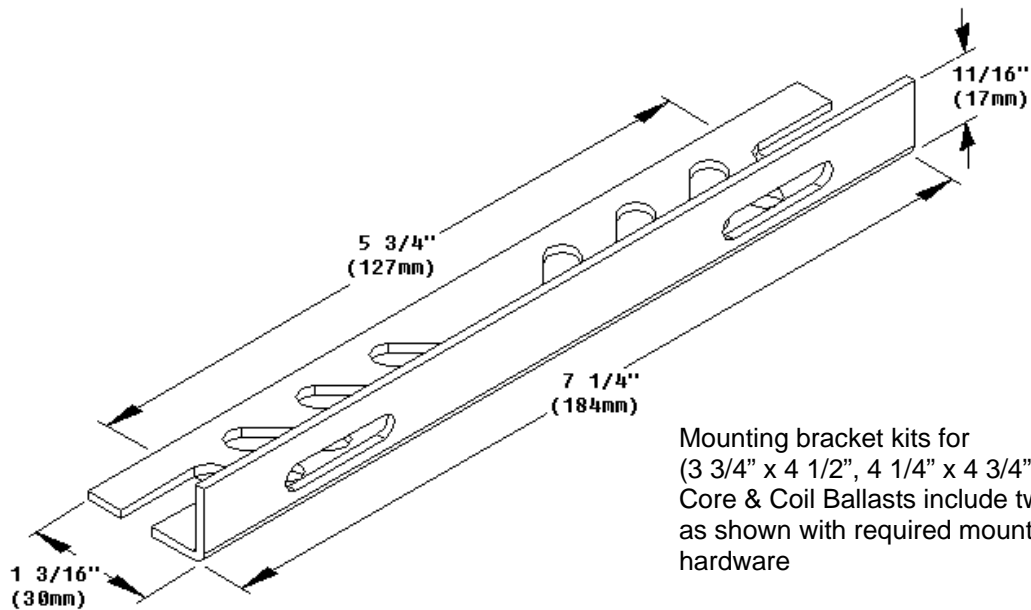

Mounting bracket kits for
(3 3/4" x 4 1/2", 4 1/4" x 4 3/4", 4 1/4" x 6")
Core & Coil Ballasts include two brackets
as shown with required mounting
hardware