

## LED Series

### LED Large Deep Hooded Semi-Cutoff Wall Pack



WH25L

#### Housing:

Die cast aluminum housing & hinged front frame, 1/2" coin plugs with O-rings for conduit & photocell, textured powdercoat finish over a chromate conversion coating

#### Mounting:

Cast-in template for mounting directly over a 4" recessed outlet box, or use 1/2" surface conduit.

#### LG LED Module:

Luminous Flux: See Chart  
 CRI: 80+, CCT: 3000K, 4000K, 5700K or 6500K  
 Operating Temperature: -40 ≈ 50°C  
 50,000 Hours  
 Module has IP67 Rating  
 RoHS Compliant  
 R9: -0.9

#### Wattage:

LED: 5 x 9 or 12w; 6 x 9 or 12w

#### Driver:

Electronic Driver, 120-277V, 50/60Hz  
 Power Factor: .90  
 Input Current: 0.9A@120VAC  
 Current: 530mA  
 THD: ≤20%  
 System Wattage: 13.6w per Module

#### Listing & Ratings:

CSA: Listed for wet locations

LM-79 Report available on select models.

#### Options:

Dimmable Driver  
 2.5KV Surge Protection

Custom colors available upon request.

# QSSI

Phone: (813) 855-9416

Fax: (813) 854-2915

Email: sales@qssi.com

### LED Large Deep Hooded Semi-Cutoff Wall Pack

Catalog #	Description	
Example: WH25LF6X12U4KZSP		
WH25	Model:	WH25
L	LED Mfr:	L=LG Innotek
F	Optics:	F=Medium Beam Spread
6X	Number of Modules:	5X=Five, 6X=Six
12	Wattage:	9=9w, 12=12w
U	Ballast:	U=120-277V
4K	CCT:	3K=3000K, 4K=4000K, 57K=5700K, 65K=6500K
Z	Color:	B=Black, Z=Bronze, W=White, G=Gray
-	Mounting:	N/A
SP	Options:	L3=HB350W-L3 Wattstopper Occupancy Sensor, 20' Height L4=HB350W-L4 Wattstopper Occupancy Sensor, 40' Height SF=Single Fuse, DF=Double Fuse, SP=Surge Protection

LD

## LED lighting facts

LED Product Partner

Total Luminous Flux per Module	CCT	Optic Type					
		C		F		I	
		12w	9w	12w	9w	12w	9w
CCT	6500K	1288	850	1345	888	1296	856
	5700K	1288	850	1345	888	1296	856
	4000K	1076	710	1100	726	1088	718
	3000K	1000	690	1030	705	1015	710

Dimensions

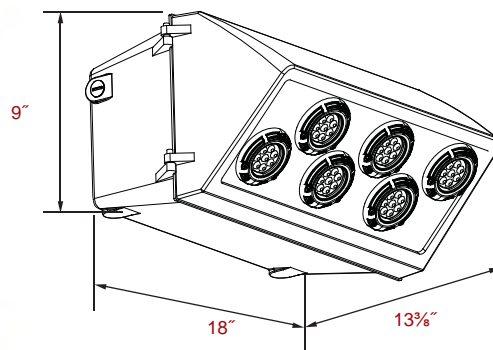

WH25L

LD-67

Catalog #	Description
HB350W-L3	Wattstopper Passive Infrared Occupancy Sensor, Wet Location, 360° Lens, 40' Diameter Coverage From 20' Height, 120/277V
HB350W-L4	Wattstopper Passive Infrared Occupancy Sensor, Wet Location, 360° Lens, 60' Diameter Coverage From 40' Height, 120/277V

LD

**LED Series**

**LED Large Deep Hooded Semi-Cutoff Wall Pack**



**HB350W-L3/L4**

■ CONTROLLED WITH *WattStopper*®

**QSSI**  
**12802 Commodity Place**  
**Tampa, FL 33626**  
**www.qssi.com**

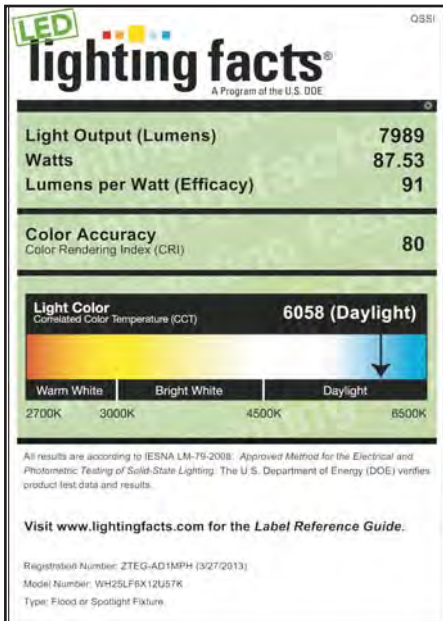

LM-79 Report available.

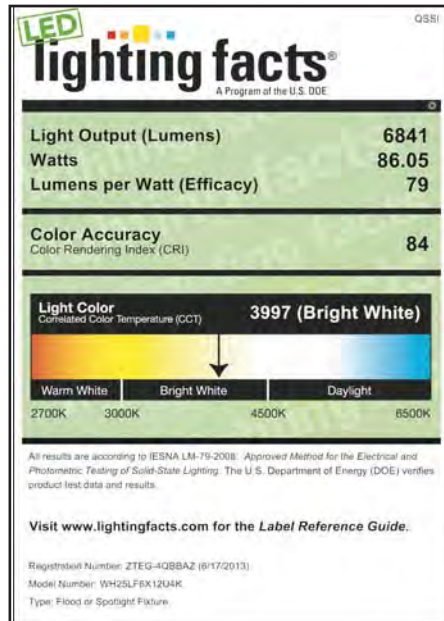

LM-79 Report available.

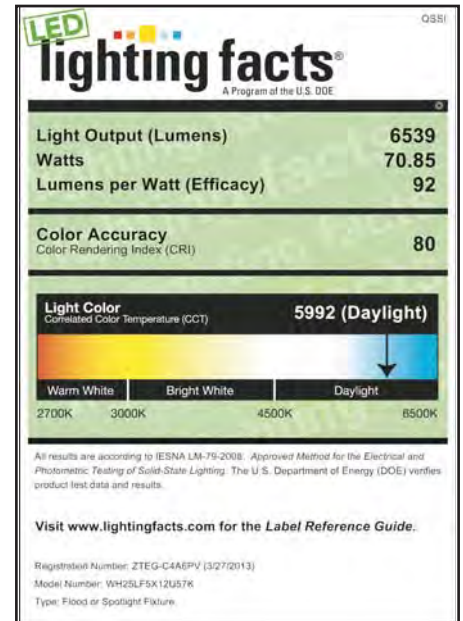

LM-79 Report available.

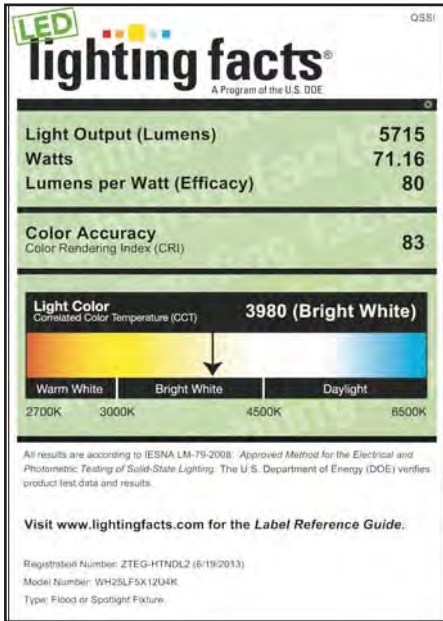

LM-79 Report available.



