

# Installation & Operation Manual



## 15 SEER MINI-SPLIT AIR CONDITIONER HEAT-PUMP

MODEL: 700500  
700505  
700510



INSTALLATION VIDEO AVAILABLE ON [www.ideal-air.com](http://www.ideal-air.com)

# Installation Manual

## IMPORTANT!

### Please Read Before Starting

This air conditioning system meets strict safety and operating standards.

As the installer or service person, it is an important part of your job to install or service the system so it operates safely and efficiently. For safe installation and trouble-free operation, you must:

Carefully read this instruction booklet before beginning.

Follow each installation or repair step exactly as shown.

Observe all local, state, and national electrical codes.

Pay close attention to all danger, warning, and caution notices given in this manual.

**WARNING:** This symbol refers to a hazard or unsafe practice which can result in severe personal injury or death.

**CAUTION:** This symbol refers to a hazard or unsafe practice which can result in personal injury and the potential for product or property damage.

\*Hazard alerting symbols



**Electrical**



**Safety/alert**

### If Necessary, Get Help

These instructions are all you need for most installation sites and maintenance conditions. If you require help for a special problem, contact our sales/service outlet or your certified dealer for additional instructions.

### In Case of Improper Installation

The manufacturer shall in no way be responsible for improper installation or maintenance service, including failure to follow the instructions in this document.

## SPECIAL PRECAUTIONS

### When Wiring

**ELECTRICAL SHOCK CAN CAUSE SEVERE PERSONAL INJURY OR DEATH. ONLY A QUALIFIED, EXPERIENCED ELECTRICIAN SHOULD ATTEMPT TO WIRE THIS SYSTEM.**

\*Do not supply power to the unit until all wiring and tubing are completed or reconnected and checked.

\*Highly dangerous electrical voltages are used in this system. Carefully refer to the wiring diagram and these instructions when wiring. Improper connections and inadequate grounding can cause accidental injury or death

\*Ground the unit following local electrical codes.

\*Connect all wiring tightly. Loose wiring may cause overheating at connection points and a possible fire hazard.

### When Transporting

Be careful when picking up and moving the indoor and outdoor units. Get a partner to help, and bend your knees when lifting to reduce strain on your back. Sharp edges or thin aluminum fins on the air conditioner can cut your fingers.

### When Installing...

...In a Ceiling or Wall

Make sure the ceiling/wall is strong enough to hold the unit's weight. It may be necessary to construct a strong wood or metal frame to provide added support.

...In a Room

Properly insulate any tubing run inside a room to prevent "sweating" that can cause dripping and water damage to walls and floors.

...In Moist or Uneven Locations

Use a raised concrete pad or concrete blocks to provide a solid, level foundation for the outdoor unit. This prevents water damage and abnormal vibration.

...In an Area with High Winds

Securely anchor the outdoor unit down with bolts and a metal frame.

Provide a suitable air baffle.

...In a Snowy Area (for Heat Pump-type Systems)

Install the outdoor unit on a raised platform that is higher than drifting snow. Provide snow vents.

### When Connecting Refrigerant Tubing

Tighten the nut with a torque wrench for a leak free connection.

Open the stop valves all the way and leave open. Check for leaks with soapy water at all refrigerant line connections.

### NOTE:

Depending on the system type, liquid and gas lines may be either narrow or wide. Therefore, to avoid confusion the refrigerant tubing for your particular model is specified as either "small" or "large" rather than as "liquid" or "gas".

### When Servicing

Turn the power OFF at the main circuit breaker panel before opening the unit to check or repair electrical parts and wiring.

Keep your fingers and clothing away from any moving parts.

Clean up the site after you finish, remembering to check that no metal scraps or bits of wiring have been left inside the unit being serviced.

After installation, explain correct operation to the customer, using the operating manual.

# Manuel d'installation

## IMPORTANT!

Veillez lire avant de commencer

Ce système de climatisation répond aux normes de la sécurité et d'exploitation strictes.

Pour le personnel de service ou d'installation, il est une partie importante de votre travail ou de service pour installer le système pour qu'il fonctionne de façon sûre et efficace. Pour la sécurité de l'installation et un fonctionnement sans problème, vous devez: Lire attentivement ce livret d'instructions avant de commencer.

Suivez chaque installation ou la réparation de l'étape exactement comme indiqué.

Observez tous les codes locaux, nationales et applicables.

Portez une attention particulière à tous les dangers, de l'alerte et avis de prudence dans ce manuel.

**AVERTISSEMENT:** Ce symbole réfère à un risque ou une utilisation dangereuse qui peut entraîner de graves blessures ou la mort.

**ATTENTION:** Ce symbole renvoie à un risque ou une pratique dangereuse qui peut entraîner des lésions corporelles et le potentiel de produits ou de dommages matériels.

## \*Symboles d'alerte



Électrique



Sécurité / avertissement

## Si nécessaire, chercher de l'aide

Ces instructions sont tout ce qu'il vous faut pour la plupart des sites d'installation et de maintenance. Si vous avez besoin d'aide pour un problème particulier, contactez notre service / ou votre revendeur agréé pour plus d' instructions.

## En cas de mauvaise installation

Le fabricant en aucun cas n'est responsable de l'installation ou service de maintenance, incluant échec de suivre les instructions de ce document.

## ATTENTION SPECIAL

**LORS DE CÂBLAGE  
ÉLECTROCUTION PEUT PROVOQUER DE  
GRAVES BLESSURES OU MORT DU PERSONNE.  
SEUL UN ÉLECTRICIEN QUALIFIÉS,  
EXPÉRIMENTÉ PEUT RACCORDER CE SYSTEME.**

\*Ne pas alimenter l'appareil jusqu'à ce que tous les câblage sont remplis ou rebranchés et vérifiées.

\*Les dangereuses électriques sont utilisées dans ce système. Consulter soigneusement le schéma de câblage et les instructions lors du câblage. Mauvais raccordements et de l'insuffisance de mise à terre peut causer des blessures ou la mort accidentelle

\*Mettre à terre l'unité en suivant les codes électriques locaux.

\*Branchez tout le câblage serrement. Le câblage lâche peut provoquer une surchauffe au point de connexion et d'un.

## Lors du transport

Soyez prudent lorsque vous ramasser et déplacer les unités de l'intérieur et l'extérieur.

Procurez vous de l'aide, et mettez vous aux genoux lors de le soulever afin de réduire la tension sur votre dos. L'arêtes pointu ou de fines ailettes en aluminium sur le conditionneur d'air peuvent couper vos doigts.

## Lors de l'installation ...

...Dans un plafond ou au mur

Assurez-vous que le plafond / mur est assez solide pour soutenir l'unité. Il peut être nécessaire de construire un cadre de bois ou de métal à fournir un appui supplémentaire.

...Dans une salle

Bien isoler les tuyaux à l' intérieur d'une salle pour empêcher "la transpiration" qui peuvent causer des gouttes d'eau et endommager les murs et les planchers.

...Dans local humide ou inégal

Utilisez un tampon de béton ou des blocs de béton ou de fournir une fondation solide et égale à l'extérieur.Cela évite les fégâts des eaux et de vibrations anormales.

...Dans un espace à vents forts

Ancrez solidement l'unité extérieure avec des boulons et un cadre métallique.

Fournir un déflecteur d'air.

...Dans un endroit de neige (pour le System de pompes à chaleur)

Installez l'unité extérieure sur une plate-forme qui est plus élevé que la poudrière.

## Lors de la connexion tubes réfrigérant

Serrer l'écrou avec une clé dynamométrique pour une connexion sans fuite.

Ouvrir les vannes d'arrêt tout le chemin et laisser ouverte.

Vérifiez pour les les fuites avec la l'eau savonneuse à tous les connexions de ligne de de fluide frigorigène.

## REMARQUE:

Selon le type de système, les tuyaux de liquides et de gaz peuvent etre soit étroite ou large. Par conséquent, pour éviter la confusion des tubes de réfrigérant, votre modèle particulier est spécifiée en marquant que "petit" ou "gros" plutôt que "liquide" ou "gaz".

## Lors de l'entretien

Éteignez-le au panneau disjoncteur principal avant d'ouvrir l'appareil pour vérifier ou réparer les composants électriques et le câblage.

Gardez vos doigts et vos vêtements à l' écart de toute pièce mobile.

Nettoyer le site après avoir fini, ne pas oublier de vérifier de pièce de métal ou de bouts de fils n' est pas laissé à l' intérieur de l'unité du service.

Après l'installation, expliquez le bon fonctionnement au client, à l'aide du manuel d'exploitation.

# Installation Manual

## This air conditioner uses new refrigerant HFC (R410A)

The basic installation work procedures are the same as conventional refrigerant (R22) models.

However, pay careful attention to the following points:

- (1) Since the working pressure is 1.6 times higher than that of conventional refrigerant (R22) models, some of the piping and installation and service tools are special. (See the table below.)  
Especially, when replacing a conventional refrigerant (R22) model with a new refrigerant R410A model, always replace the conventional piping and flare nuts with the R410A piping and flare nuts.
- (2) Models that use refrigerant R410A have a different charging port thread diameter to prevent erroneous charging with conventional refrigerant (R22) and for safety. Therefore, check beforehand. [The charging port thread diameter for R410A is 1/2 threads per inch.]
- (3) Be more careful that foreign matter (oil, water, etc.) does not enter the piping than with refrigerant (R22) models. Also, when storing the piping, securely seal the opening by pinching, taping, etc.
- (4) When charging the refrigerant, take into account the slight change in the composition of the gas and liquid phases, and always charge from the liquid phase side whose composition is stable.

### Special tools for R410A

Tool name	Contents of change
Gauge manifold	Pressure is high and cannot be measured with a conventional gauge. To prevent erroneous mixing of other refrigerants, the diameter of each port has been changed. It is recommended the gauge with seals -0.1 to 5.3 MPa (-1 to 53 bar) for high pressure, -0.1 to 3.8 MPa (-1 to 38 bar) for low pressure.
Charge hose	To increase pressure resistance, the hose material and base size were changed.
Vacuum pump	A conventional vacuum pump can be used by installing a vacuum pump adapter.
Gas leakage detector	Special gas leakage detector for HFC refrigerant R410A.

### Copper pipes

It is necessary to use seamless copper pipes and it is desirable that the amount of residual oil is less than 40 mg/10m. Do not use copper pipes having a collapsed, deformed or discolored portion (especially on the interior surface). Otherwise, the expansion valve or capillary tube may become blocked with contaminants.

As an air conditioner using R410A incurs pressure higher than when using R22, it is necessary to choose adequate materials.

Thicknesses of copper pipes used with R410A are as shown in the table. Never use copper pipes thinner than that in the table even when it is available on the market.

thickness of annealed copper pipe		
Nominal diameter	Outer diameter	Thickness
1/4in	6.35mm	0.8mm
3/8in	9.52mm	0.8mm
1/2in	12.7mm	0.8mm
5/8in	15.88mm	1.0mm

#### WARNING

- (1) Do not use the existing (for R22) piping and flare nuts.  
• If the existing materials are used, the pressure inside the refrigerant cycle will rise and cause breakage, injury, etc. (Use the special R410A materials.)
- (2) When installing and relocating the air conditioner, do not mix gases other than the specified refrigerant (R410A) to enter the refrigerant cycle.  
• If air or other gas enters the refrigerant cycle, the pressure inside the cycle will rise to an abnormally high value and cause breakage, injury, etc.

#### CAUTION

When installing pipes shorter than 10 ft (3m), sound of the outdoor unit will be transferred to the indoor unit, which will cause large operating sound or some abnormal sound.

# Installation Manual

## GENERAL

This INSTALLATION MANUAL briefly outlines where and how to install the air conditioning system. Please read over the entire set of instructions for the indoor and outdoor units and make sure all accessory parts listed are with the system before beginning.

### 3. OPERATING RANGE

	Cooling/Dry Mode	Heating Mode
Outdoor temperature	-10C(14F)~52C(125F)	-23C(-10F)~23C(75F)
Indoor temperature	16C(60F)~30C(90F)	10C(50F)~30C(90F)
Indoor humidity	80%	-

### ADDITIONAL CHARGE

Refrigerant suitable for a piping length of 25 ft (7.5 m) is charged in the outdoor unit at the factory.

When the piping is longer than 25 ft (7.5 m), additional charging is necessary. For the additional amount, see the table below.

Table 5

Pipe length	25 ft (7.5 m)	33 ft (10 m)	49 ft (15 m)	66 ft (20 m)	83 ft (25 m)
Additional refrigerant	None	1.8 oz (50 g)	5.3 oz (150 g)	3.5 oz (100 g)	9.0 oz (200 g)

Between 25 ft (7.5 m) and 49 ft (15 m), when using a connection pipe other than that in the table, charge additional refrigerant with 0.7 OZ/ 3.3 ft (20g/1 m) as the criteria.

### CAUTION

- (1) When adding refrigerant, add the refrigerant from the charging port at the completion of work.
- (2) The maximum length of the piping is 15 m. If the units are further apart than this, correct operation can not be guaranteed.

## ELECTRICAL REQUIREMENT

Always make the air conditioner power supply a special branch circuit and provide a special switch and receptacle. Do not extend the power cord.

### CAUTION

	12KBTU	24KBTU	36KBTU
MINIMUM CIRCUIT AMPACITY	15A	21A	22A
MAXIMUM OVERCURRENT PROTECTION (TIME DELAY FUSE OR HACR TYPE CIRCUIT BREAKER)	20A	25A	30A

## STANDARD ACCESSORIES

The following installation accessories are supplied. Use them as required.

### INDOOR UNIT ACCESSORIES

Installation Accessories Name	Q'ty	Use
Wall hook bracket	1	For indoor unit installation
Remote controller	1	Use for air conditioner operation
Battery	2	For remote control unit
Drain Pipe	1	For indoor unit installation
Wall Caps	1	For indoor unit installation
Wall Pipe	1	For indoor unit installation
Thermostat Pigtail	1	For Thermostat connection
Outdoor unit bracket	1	For outdoor unit installation

# Installation Manual

## SELECTING THE MOUNTING POSITION

Decide the mounting position with the customer as follows:

### 1. INDOOR UNIT

- (1) Install the indoor unit level on a strong wall which is not subject to vibration.
- (2) The inlet and outlet ports should not be obstructed : the air should be able to blow all over the room.
- (3) Install the unit near an electric outlet or special branch circuit.
- (4) Do not install the unit where it will be exposed to direct sunlight.
- (5) Install the unit where connection to the outdoor unit is easy.
- (6) Install the unit where the drain pipe can be easily installed.
- (7) Take servicing, etc. into consideration and leave the spaces shown in (Fig. 2). Also install the unit where the filter can be removed.

### 2. OUTDOOR UNIT

- (1) If possible, do not install the unit where it will be exposed to direct sunlight. (If necessary, install a blind that does not interfere with the air flow.)
- (2) Do not install the unit where a strong wind blows or where it is very dusty.
- (3) Do not install the unit where people pass.
- (4) Take you neighbors into consideration so that they are not disturbed by air blowing into their windows or by noise.
- (5) Provide the space shown in Fig. 2 so that the air flow is not blocked. Also for efficient operation, leave open three of the four directions front, rear, and both sides.

#### ⚠ WARNING

**Install at a place that can withstand the weight of the indoor and outdoor units and install positively so that the units will not topple or fall.**

#### ⚠ CAUTION

- (1) **Do not install where there is the danger of combustible gas leakage.**
- (2) **Do not install near heat sources.**
- (3) **If children under 10 years old may approach the unit, take preventive measures so that they cannot reach the unit.**

### [Indoor unit piping direction]

The piping can be connected in the 6 directions indicated in (Fig. 6). When the piping is connected in direction 2,3,4 or 5, cut along the piping groove in the side of the front cover with a hacksaw.

Fig. 6

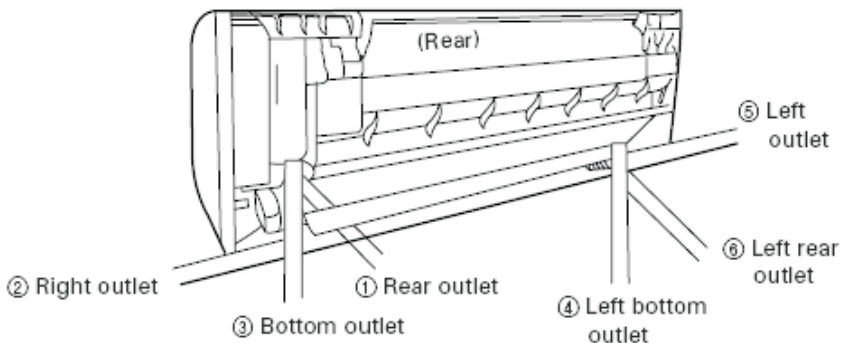

# Installation Master Plan

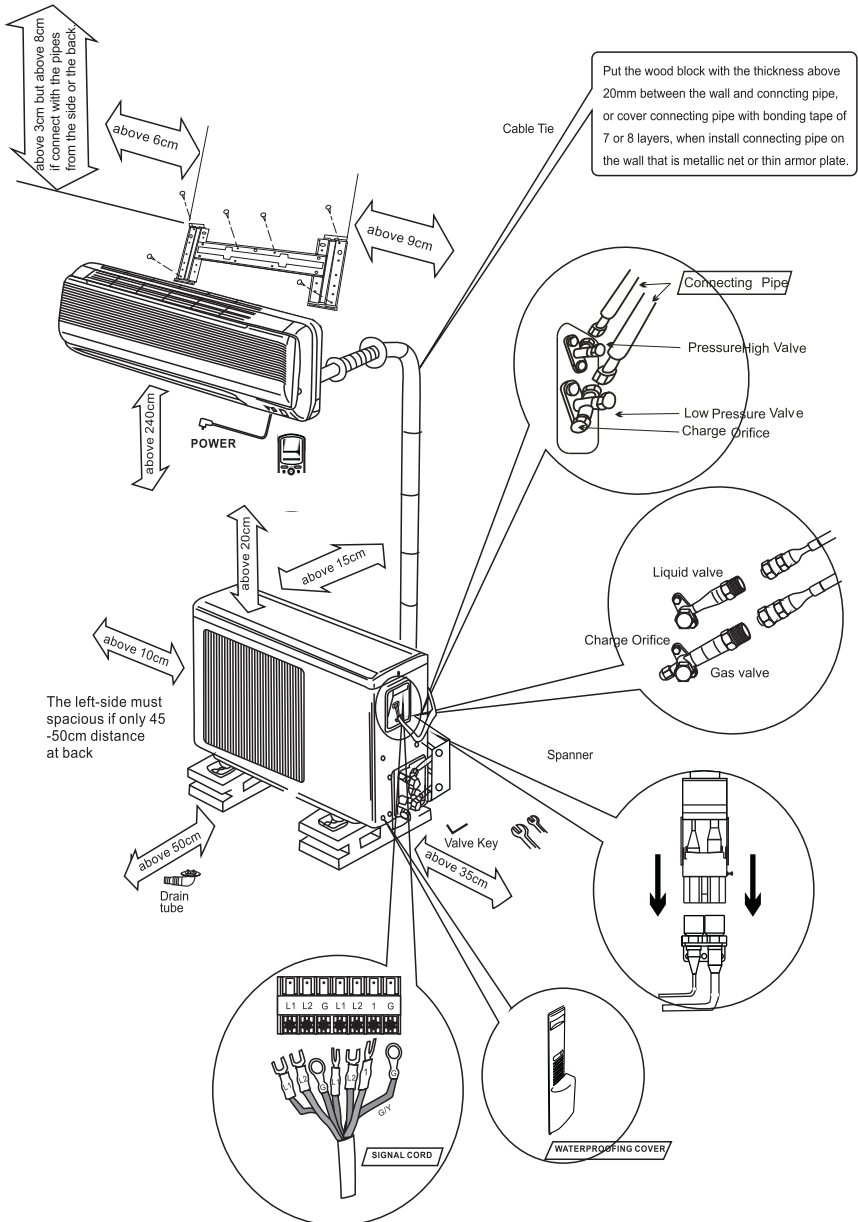

120V,60HZ 230V,60HZ

# Installation Manual

## INDOOR UNIT

### 1. CUTTING THE HOLE IN THE WALL FOR THE CONNECTING PIPING

(1) Cut a 3-2/16" (80 mm) diameter hole in the wall at the position shown in (Fig.1).

(2) When cutting the wall hole at the inside of the installation frame, cut the hole within the range of the left and right center marks 3/8" (10 mm) below the installation frame.

When cutting the wall hole at the outside of the installation frame, cut the hole at least 3/8" (10 mm) below less.

(3) Cut the hole so that the outside end is lower 3/16" to 3/8" (5 to 10 mm) than the inside end.

(4) Always align the center of the wall hole. If misaligned, water leakage will occur.

(5) Cut the wall pipe to match the wall thickness, stick it into the wall cap, fasten the cap with vinyl tape, and stick the pipe through the hole (The connection pipe is supplied in the installation set.) (Fig.1)

(6) For left piping and right piping, cut the hole a little lower so that drain water will flow freely. (Fig.1)

Fig. 1

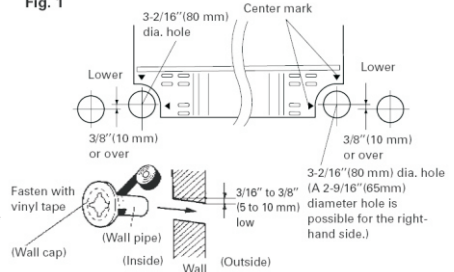

### 2. INSTALLING THE WALL HOOK BRACKET

(1) Install the wall hook bracket so that it is correctly positioned horizontally and vertically. If the wall hook bracket is tilted, water will drip to the floor.

(2) Install the wall hook bracket so that it is strong enough to withstand the weight of an adult.

- Fasten the wall hook bracket to the wall with 6 or more screws through the holes near the outer edge of the bracket.
- Check that there is no rattle at the wall hook bracket.

#### ⚠ WARNING

If the wall pipe is not used, the cord interconnecting the indoor and outdoor units may touch metal and cause electric leakage.

#### ⚠ CAUTION

Install the wall hook bracket horizontally and perpendicularly.

Fig.2

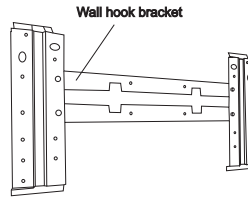

### 3. FORMING THE DRAIN HOSE AND PIPE

[Rear piping, Right piping, Bottom piping]

\*Install the indoor unit piping in the direction of the wall hole and bind the drain hose and pipe together with vinyl tape. (Fig. 3)

\*Install the piping so that the drain hose is at the bottom.

\*Wrap the pipes of the indoor unit that are visible from the outside with decorative tape.

[For Left rear piping, Left piping]

Interchange the drain cap and the drain hose.

#### ⚠ CAUTION

- (1) In order to align the drain hose and drain cap, be sure to insert securely and vertically. Incline insertion will cause water leakage.
- (2) When inserting, be sure not to attach any material besides water. If any other material is attached, it will cause deterioration and water leakage.
- (3) After removing drain hose, be sure not to forget mounting drain cap.
- (4) Be sure to fix the drain hose with tape to the bottom of piping.
- (5) Prevent drain water frozen under low temperature environment. When installing indoor unit's drain hose outdoors, necessary measure for frost protection should be taken to prevent drain water frozen.

Fig. 3

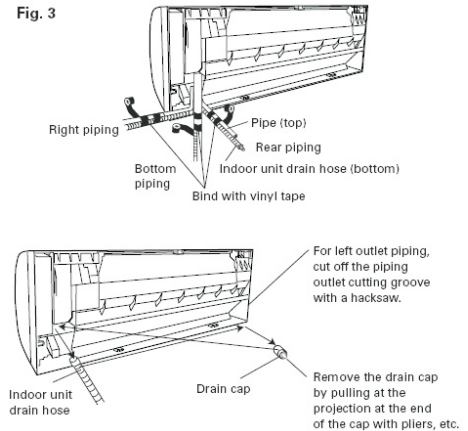



# Installation Manual

## OUTDOOR UNIT

### OUTDOOR UNIT INSTALLATION

- Set the unit on a strong stand, such as one made of concrete blocks to minimize shock and vibration.
- Do not set the unit directly on the ground because it will cause trouble.

### Connector cover removal

- Remove the two mounting screws.

### Installing the connector cover

- (1) After inserting the three front hooks, then insert the rear hook.
- (2) Tighten the two mounting screws.



- (1) Install the unit where it will not be tilted by more than 5°.
- (2) When installing the outdoor unit where it may be exposed to strong wind, fasten it securely.

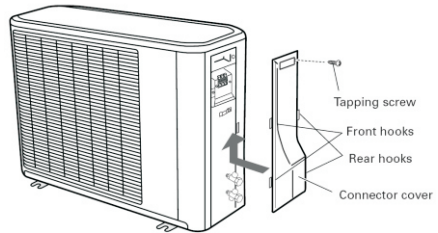

Always use the screws as shown above.  
Do not select the top and bottom screws incorrectly.



- (1) Refrigerant must not be discharged into atmosphere.
- (2) After connecting the piping, check the joints for gas leakage with gas leak detector.

	Tightening torque
Blank cap (2-way valve)	14.47 to 18.08 ft•lbs (200 to 250 kgf•cm)
Blank cap (3-way valve)	20.25 to 23.15 ft•lbs (280 to 320 kgf•cm)
Charging port cap	9.04 to 11.57 ft•lbs (125 to 160 kgf•cm)

# Installation Manual

## Installation of Quick Connector Between Indoor and Outdoor Unit

### **【 Pipelines connection for Whole-Unit type quick coupler model】**

● If you purchase the machine for Whole-Unit type quick coupler model, please adopt the following pipelines connection procedures:

#### STEP 1

● Remove two screws on the maintenance plate with a screwdriver and take off the plate, then remove the dust caps on both indoor male coupler and outdoor female coupler, See Fig.9.

Fig.9

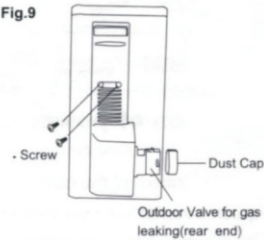

#### STEP 2

● Press the projecting section of outdoor female coupler backward with a little force by the thumb to make inner hooks open, and then you can easily take out the outdoor valve for gas leaking by the other hand, See Fig.10.

Fig.10

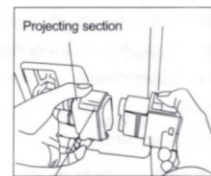

#### STEP 3

● In the same way, press the projecting section backward, then connect the indoor male coupler to the outdoor female coupler, See Fig.11.

Outdoor female coupler (With movable sheath) Outdoor Valve for gas leaking

#### STEP 4

● Close the key lever of indoor male coupler to the horizontal position, then indoor and outdoor refrigerant will be circulating, and now you can obviously hear the sound of inner air flowing, See Fig.12.

Fig.11

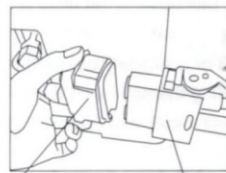

Outdoor female coupler Indoor male coupler

#### STEP 5

● Connect the outdoor quick cable coupler with indoor quick cable coupler, See Fig.13.

#### STEP 6

● Finally, Re-install the maintenance plate back into its place, See Fig.14.

As for the outdoor valve for gas leaking and the dust caps, you can preserve them for future possible use on the removal of your air conditioner.

Fig.12

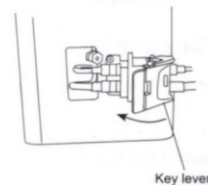

Key lever

# Installation Manual

---

## Screw Connection

- Remove the waterproofing covers on the outdoor unit quick connectors.
- Inspect both quick connectors on outdoor unit and lineset for debri, clean if necessary.
- If debri is allowed to enter system, damage may occur.
- Connect the quick connect fittings to the outdoor unit valves with 2 wrenches.

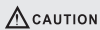

DO NOT OVER TIGHTEN, DAMAGE & LEAKAGE WILL OCCUR.

- Remove the brass caps on the two valves with a wrench.
- Open the liquid valve & gas valve with an allen wrench.
- Reinstall the brass caps on the valves.
- Gas leakage Inspection:

After connecting the piping, check all connections & caps for leakage carefully, soapy water or an electronic refrigerant detector can be used.

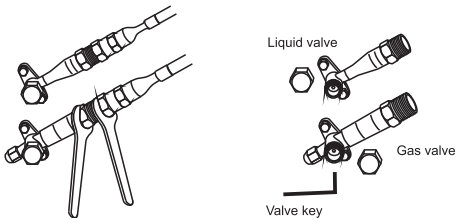

# Installation Manual

- If the air conditioner needs to be disconnected and moved to another place, please recycle the gas back into the compressor according to the following steps before doing the disconnecting:

1. Start the A/C, operate in Cooling mode.
2. Remove the cap of the two valves with a wrench.

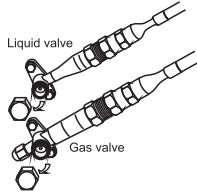

3. Tighten the core of the liquid valve (the smaller one) with valve key at first. After about 20 seconds, tighten the core of the gas (the bigger one) with valve key. Turn off the a/c at once and cut off the power supply.

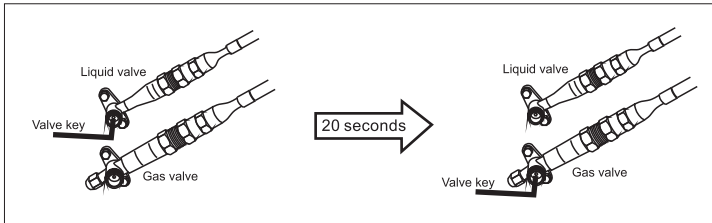

4. Tighten the cap of two valves.

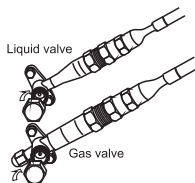

5. Disconnect the power cable from outdoor unit.
6. Loose the nut of the quick connect pipe from the outdoor unit valve with 2 wrenches

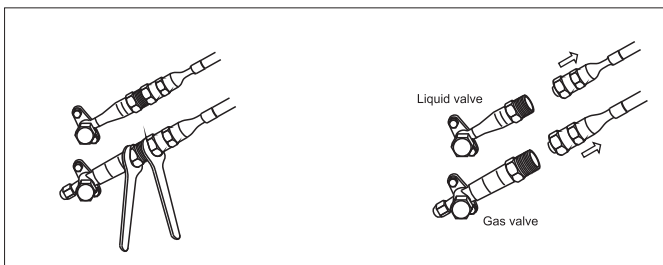

**CAUTION**

**INSURE NO DEBRI ENTERS THE QUICK CONNECTS.  
IF DEBRI IS ALLOWED TO ENTER SYSTEM, DAMAGE MAY OCCUR.**

# Electrical Wiring Diagram

## 12000Btu/h Electrical Wiring Diagram

### Outdoor Unit(120V/60HZ)

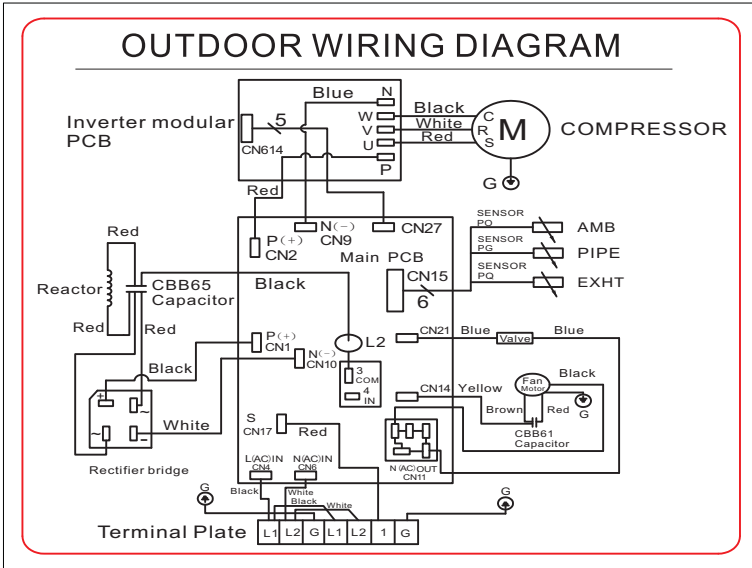

### Indoor Unit(120V/60HZ)

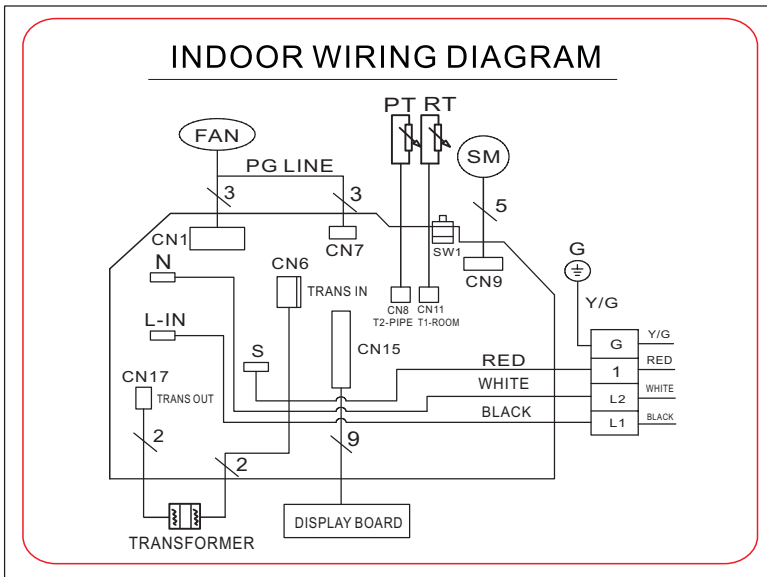

# Electrical Wiring Diagram

## 18000Btu/h-Electrical Wiring Diagram

### Outdoor Unit (230V/60HZ,220V/50HZ)

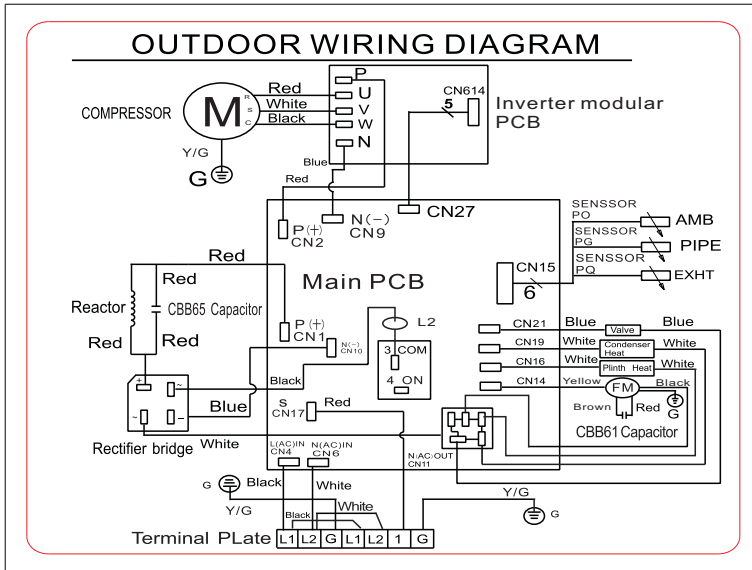

### Indoor Unit (230V/60HZ,220V/50HZ)

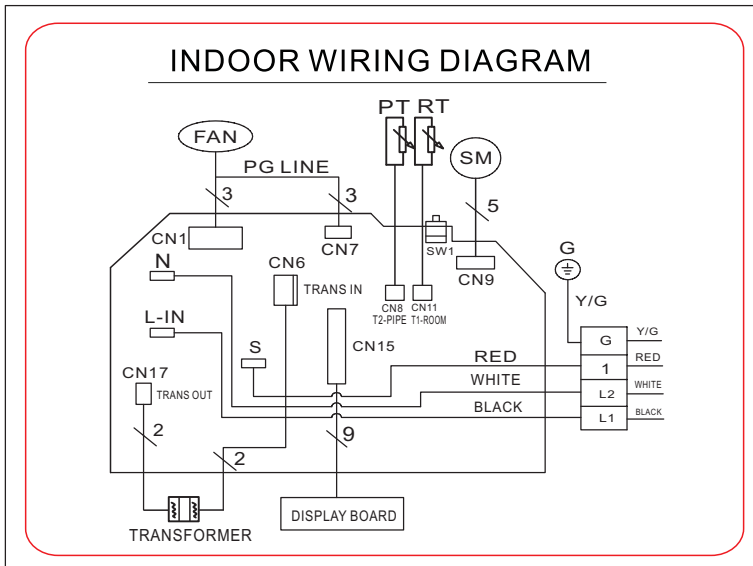

# Electrical Wiring Diagram

## 24000Btu/h Electrical Wiring Diagram

### Outdoor Unit (230V/60HZ,220V/50HZ)

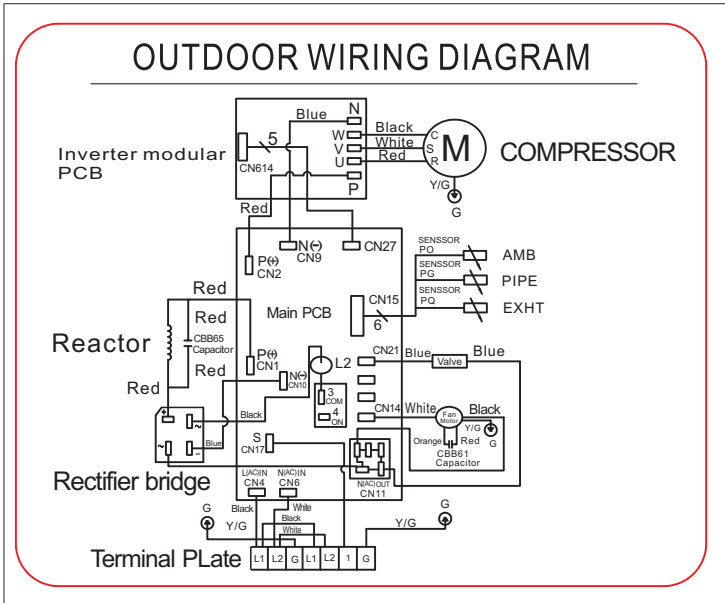

### Indoor Unit (230V/60HZ,220V/50HZ)

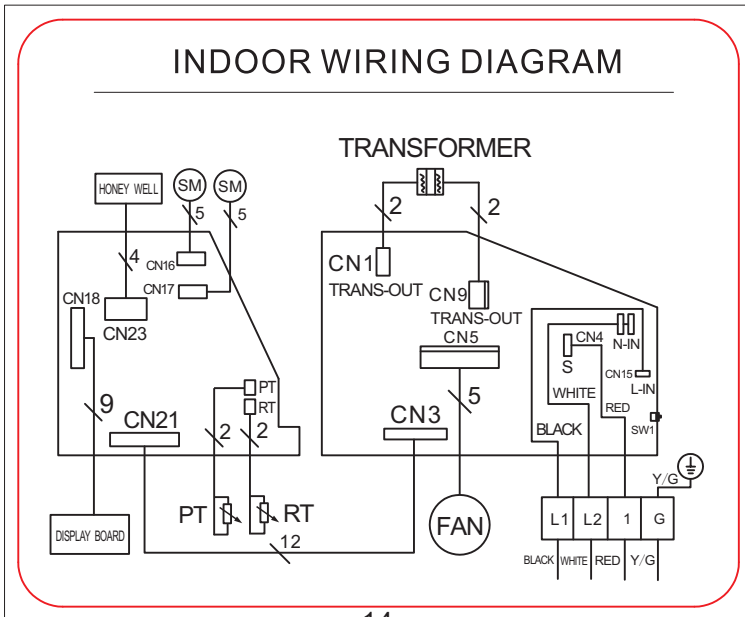

# Electrical Wiring Diagram

## 36000Btu/h Electrical Wiring Diagram

### Outdoor Unit (230V/60HZ,220V/50HZ)

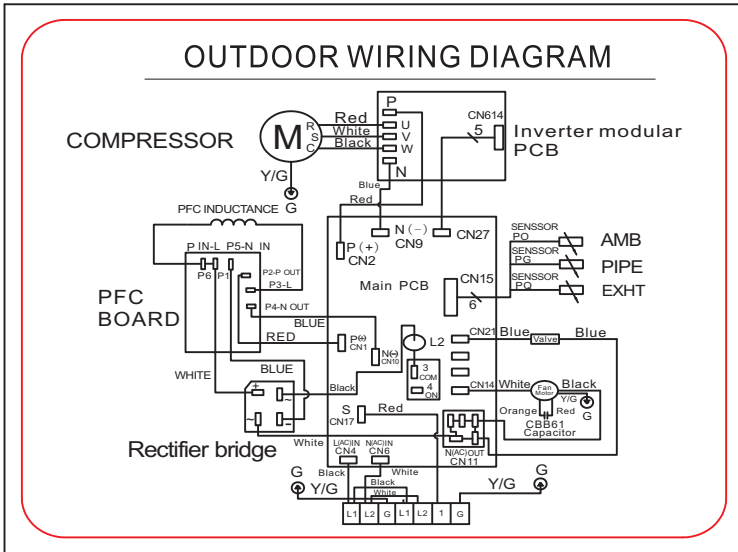

### Indoor Unit (230V/60HZ,220V/50HZ)

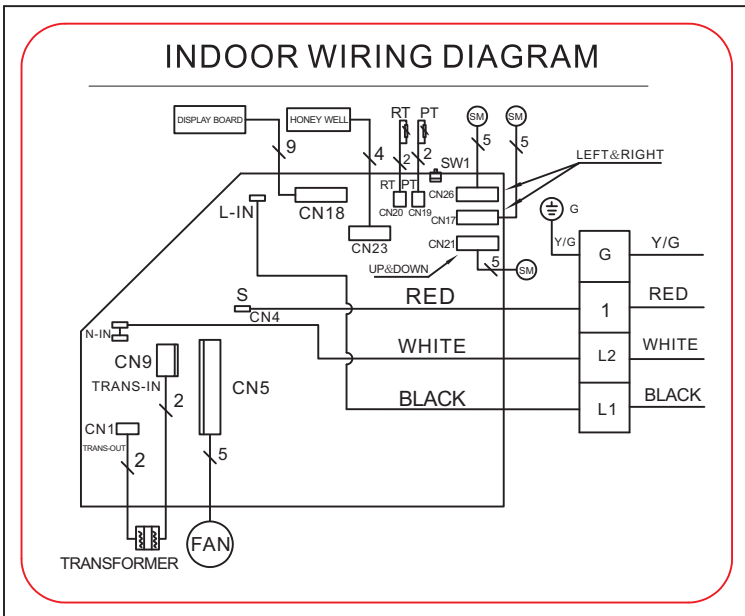



# Installation Manual

---

## INDOOR PCB & OUTDOOR MAIN PCB & INVERTER MODULAR PCB

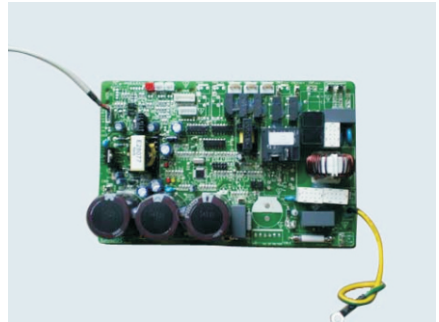
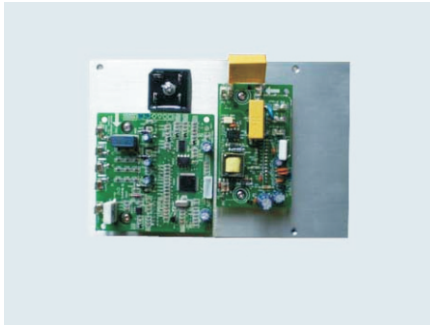

**36KBTU Outdoor Inverter Modular PCB 12K/18K/24/36KBTU Outdoor Main PCB**

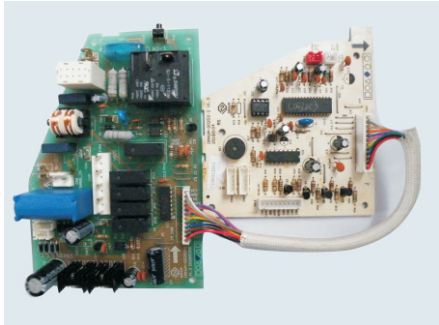
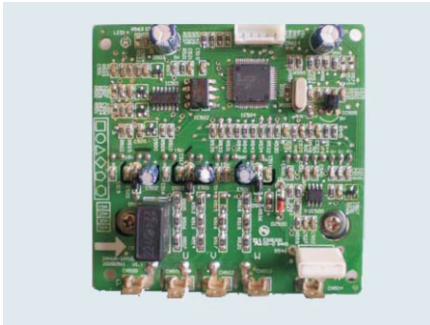

**12K/18K/24K Outdoor Inverter Modular PCB**

**24KBTU Indoor PCB**

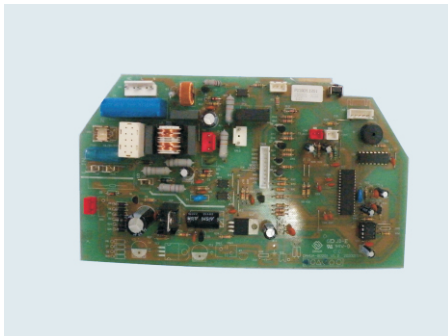

**12K/18KBTU Indoor PCB**

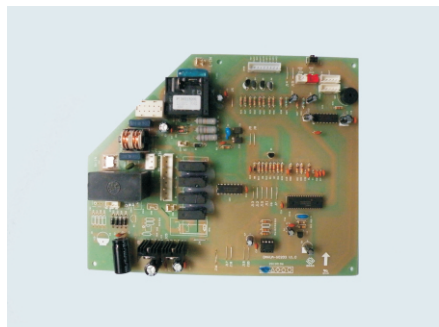

**36KBTU Indoor PCB**

# Installation Manual

## Indoor Unit Electrical Wiring

1. Remove the screws, then remove the cord clamp.
2. Connect connection cord to the terminal. Refer to the wiring diagram
3. Use the screws to install the cord clamp.

Indoor unit terminal block

outdoor unit terminal block

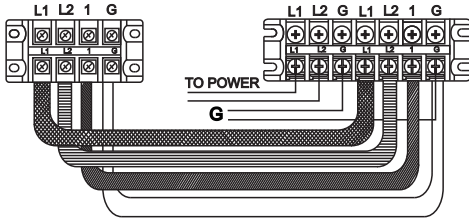

**120v/60hz power**  
**12kbtu**

**230v/60hz power**  
**24kbtu 36kbtu**

### HOW TO CONNECT WIRING TO THE TERMINALS

#### A. For solid core wiring (or F-cable)

- (1) Cut the wire end with a wire cutter or wire-cutting pliers, then strip the insulation to about 15/16" (25 mm) to expose the solid wire.
- (2) Using a screwdriver, remove the terminal screw(s) on the terminal board.
- (3) Using pliers, bend the solid wire to form a loop suitable for the terminal screw.
- (4) Shape the loop wire properly, place it on the terminal board and tighten securely with the terminal screw using a screwdriver.

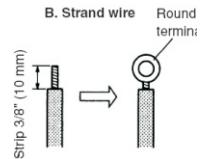
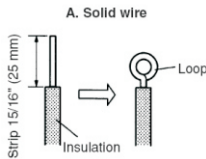

#### B. For strand wiring

- (1) Cut the wire end with a wire cutter or wire-cutting pliers, then strip the insulation to about 3/8" (10 mm) to expose the strand wiring.
- (2) Using a screwdriver, remove the terminal screw(s) on the terminal board.
- (3) Using a round terminal fastener or pliers, securely clamp a round terminal to each stripped wire end.
- (4) Position the round terminal wire, and replace and tighten the terminal screw using a screwdriver.

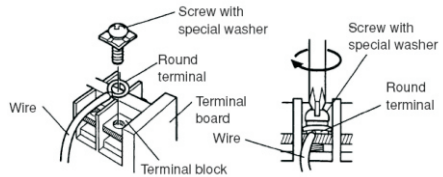

### CAUTION

(1) Match the terminal block numbers and connection cord colors with those of the outdoor unit. Erroneous wiring may cause burning of the electric parts.

(2) Connect the connection cords firmly to the terminal block. Imperfect installation may cause a fire.

(3) Always fasten the outside covering of the connection cord with the cord clamp. (If the insulator is chafed, electric leakage may occur.)

(4) Securely earth the power cord plug.

(5) Do not use the earth screw for an external connector. Only use for interconnection between two units.

# Installation Manual

## Outdoor Unit Electrical Wiring

- Remove the electric box access cover.
- Connect the electric cable to the terminal by the number.
- Secure the cables with cable clamp.
- Fix back the access cover.

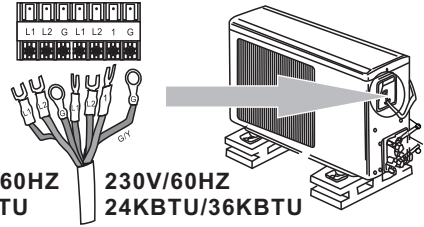

### ⚠ WARNING

Be sure to comply with local codes while running the wire from the indoor unit to the outdoor unit (size of wire and wiring method, etc. ).

Every wire must be connected firmly.

No wire should be allowed to touch refrigerant tubing, the compressor or any moving part.

Loose wiring may cause the terminal to overheat or result in unit malfunction. A fire hazard may also exist. Therefore, be sure all wiring is tightly connected.

Connect wires to the matching numbers & colors of terminals.

### ⚠ CAUTION

(1) The power source capacity must be the sum of the air conditioner current and the current of other electrical appliances. When the current contracted capacity is insufficient, change the contracted capacity.

(2) When the voltage is low and the air conditioner is difficult to start, contact the power company the voltage raised.

### POWER

#### ⚠ WARNING

- (1) The rated voltage of this product is 120v/60hz for 12kbtu unit, 230v/60hz for 24kbtu & 36kbtu unit.
- (2) Before turning on the power, check if the voltage is within the rated voltage  $\pm 10\%$ .
- (3) Always use a special branch circuit and install a special receptacle to supply power to the room air conditioner.
- (4) Use a circuit breaker and receptacle matched to the capacity of the air conditioner.
- (5) Do not extend the power cord.
- (6) Perform wiring work in accordance with standards so that the air conditioner can be operated safely and positively.
- (7) Install a leakage circuit breaker in accordance with the related laws and regulations and electric company standards.

### CUSTOMER GUIDANCE

Explain the following to the customer in accordance with the operating manual:

- (1) Starting and stopping method, operation switching, temperature adjustment, timer, air flow switching, and other remote control unit operations.
- (2) Air filter removal and cleaning, and how to use the air louvers.
- (3) Give the operating and installation manuals to the customer.

### PUMP DOWN OPERATION

To avoid discharging refrigerant into the atmosphere at the time of relocation or disposal, recover refrigerant by doing the cooling operation according to the following procedure.

- (1) Do the air purging of the charge hose by connecting the charging hose of gauge manifold to the charging port of 3 way valve and opening the low-pressure valve slightly.
  - (2) Close the valve stem of 2 way valve completely.
  - (3) Start the cooling operation. When using the remote control unit Press the MODE button after starting the cooling operation by the remote control uni).
  - (4) Close the valve stem of 3 way valve when the reading on the compound pressure gage becomes 0.05~0 Mpa (0.5~0 kg/cm<sup>2</sup>).
  - (5) Stop the operation.
- Press the START/STOP button of the remote control unit to stop the operation.

#### ⚠ CAUTION

During the pump-down operation, make sure that the compressor is turned off before you remove the refrigerant piping. Do not remove the connection pipe while the compressor is in operation with 2 way or 3 way valve open. This may cause abnormal pressure in the refrigeration cycle that leads to breakage and even injury.

# Installation Manual

## Drain Piping

- The drain pipe should point downward for easy drain flow.(Fig.1)  
Do not make drain piping as shown in Fig.2 to 5.

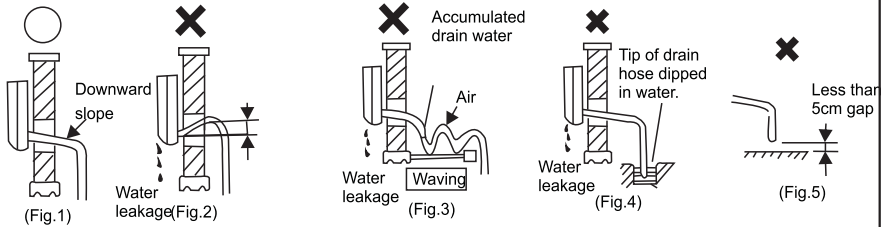

- If the piping runs to the left as shown in the right figure, seal the drain port on the right with the plug and connect the drain pipe on the left.

Check that:

- 1) The top and bottom hooks are hooked firmly.
  - 2) The main unit is accurately positioned horizontally and vertically. If the unit is not installed properly, water will drip onto the floor.
  - 3) The drain pipe is not bent upwards as shown in the figure.
- Connect the drain pipe with extension drain hose  
If the extension drain pipe has to pass through a room,  
be sure to wrap with commercially soil insulation.

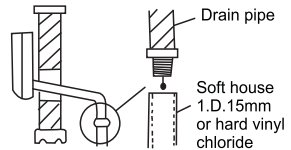
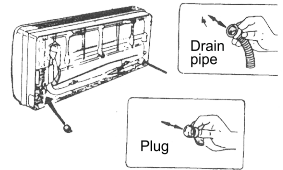

## TEST RUNNING

- Perform test operation and check items 1 and 2 below.
- For the test operation method, refer to the operating manual.
- The outdoor unit, may not operate, depending on the room temperature. In this case, press the test run button on the remote control unit while the air conditioner is running, (use a metallic object to short the two metal contacts under the battery compartment lid and send the "TEST RUN" signal from the remote control unit.)
- To end test operation, press the remote control unit START/STOP button.(When the air conditioner is run by pressing the test run button, the OPERATION indicator lamp and TIMER indicator lamp will simultaneously flash slowly.)

### 1. INDOOR UNIT

- (1) Is operation of each button on the remote control unit normal?
- (2) Does each lamp light normally?
- (3) Do the air flow-direction louver operate normally?
- (4) Is the drain normal?

### 2. OUTDOOR UNIT

- (1) Is there any abnormal noise and vibration during operation?
- (2) Will noise, wind, or drain water from the unit disturb the neighbors?
- (3) Is there any gas leakage?

# Operation Manual

---

## SAFETY PRECAUTIONS



Do not attempt to install this air conditioner by yourself.

This unit contains no user-serviceable parts. Always consult authorized service personnel for repairs.

When moving, consult authorized service personnel for disconnection and installation of the unit.

Do not become excessively chilled by staying for lengthy periods in the direct cooling airflow.

Do not insert fingers or objects into the outlet port or intake grilles.

Do not start and stop air conditioner operation by disconnecting the power supply cord and so on.

Take care not to damage the power supply cord.

In the event of a malfunction (burning smell, etc.), immediately stop operation, disconnect the power supply plug, and consult authorized service personnel.

If the power supply cord of this appliance is damaged, it should only be replaced by the authorized service personal, since special purpose tools and specified cord are required.



Provide occasional ventilation during use.

Do not direct air flow at fireplaces or heating apparatus.

Do not climb on, or place objects on, the air conditioner.

Do not hang objects from the indoor unit.

Do not set flower vases or water containers on top of air conditioners.

Do not expose the air conditioner directly to water.

Do not operate the air conditioner with wet hands.

Do not pull power supply cord.

Turn off power source when not using the unit for extended periods.

Check the condition of the installation stand for damage.

Do not place animals or plants in the direct path of the air flow.

Do not drink the water drained from the air conditioner.

Do not use in applications involving the storage of foods, plants or animals, precision equipment, or art works.

Do not apply any heavy pressure to radiator fins.

Operate only with air filters installed.

Do not block or cover the intake grille and outlet port.

Ensure that any electronic equipment is at least one metre away from either the indoor or outdoor units.

Avoid installing the air conditioner near a fireplace or other heating apparatus.

When installing the indoor and outdoor unit, take precautions to prevent access to infants.

Do not use inflammable gases near the air conditioner.

# Operation Manual

## Descriptions of Parts

### Indoor Unit

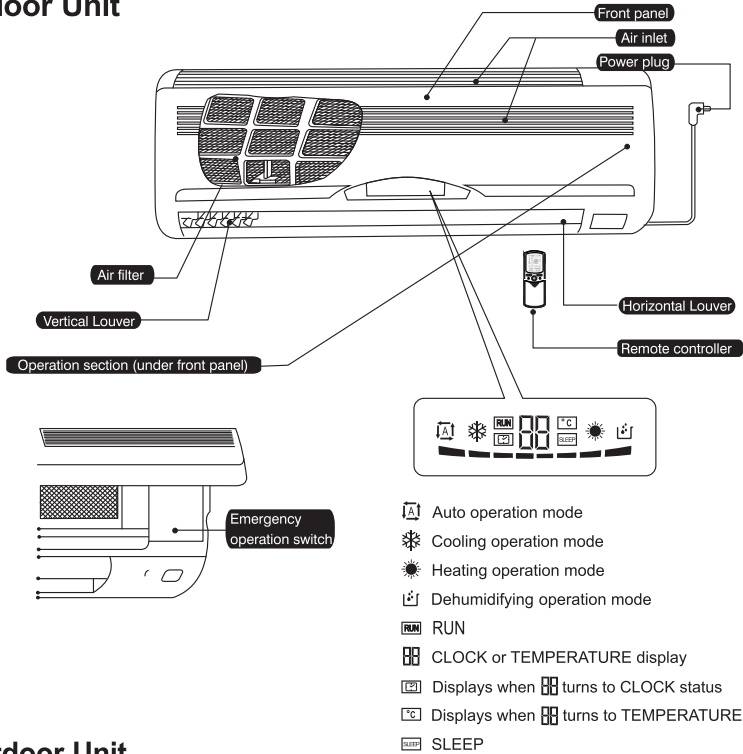

### Outdoor Unit

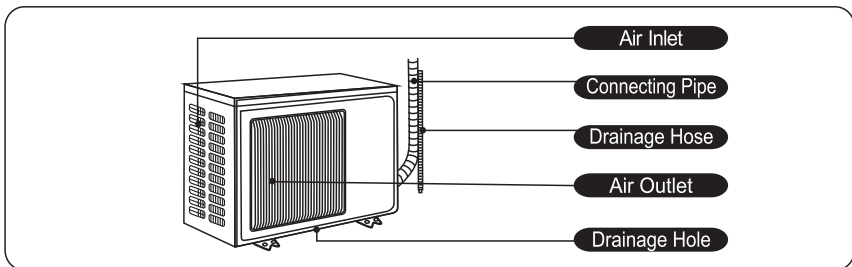

The figures of indoor unit and outdoor are only simple presentation of the appearance of the application; it may not conform with actual one your purchased.

# Operation Manual

## Parts List

### Indoor Unit

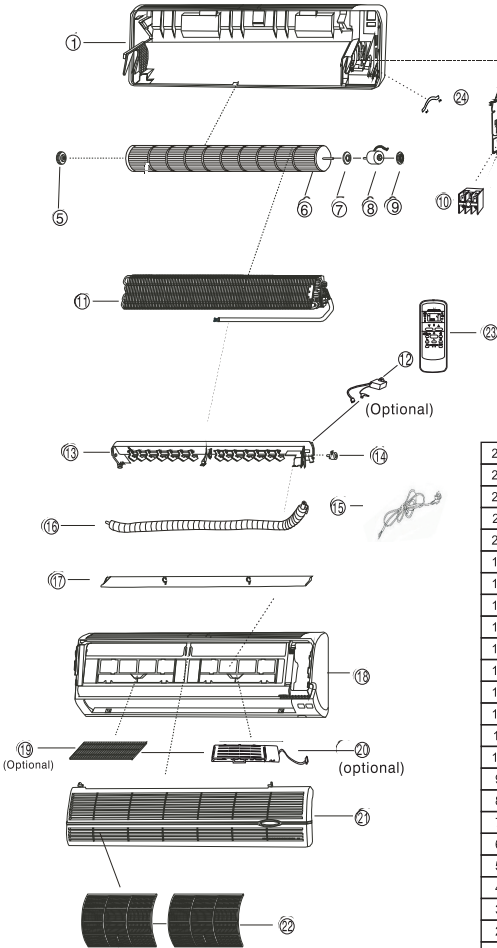

24	Fan motor cover	1
23	Remote controller	1
22	Filter	1
21	Air intake grill	1
20	Plasma	1
19	Photo catalyzer filter	1
18	Front cover	1
17	Louver	1
16	Drain hose	1
15	Power cable with plug	1
14	Step motor	1
13	Air deflector assembly	1
12	Iniozer	1
11	Evaporator	1
10	Terminal block	1
9	Motor bearing right	1
8	Blower motor	1
7	Motor bearing left	1
6	Blower	1
5	Blower bearing	1
4	PCB	1
3	Electric box cover	1
2	Electric box	1
1	Back cover	1
No	Name	Q'ty

# Operation Manual

## Parts List

### Outdoor Unit

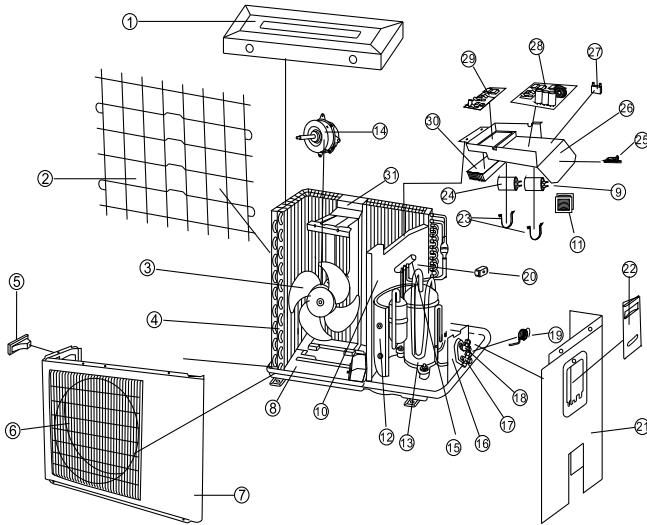

NO.	NAME	Q'TY	NO.	NAME	Q'TY
1	Top panel	1	17	Gas valve	1
2	Back grill	1	18	Liquid valve	1
3	Outdoor fan	1	19	Capillary	1
4	Condenser	1	20	Rev valve coil	1
5	Handle	1	21	Side panel	1
6	Front grill	1	22	Access plate	1
7	Front panel	1	23	Capacitor clips	1
8	Bottom plate	1	24	Compressor capacitor	1
9	filter capacitor	1	25	Wire clip	1
10	Partition board	1	26	Electric box	1
11	Reactor	1	27	Fan motor capacitor	1
12	Compressor jacket	1	28	Outdoor PCB	1
13	Compressor	1	29	Module	1
14	Outdoor motor	1	30	Radiator	1
15	Reversing valve	1	31	Motor bracket	1
16	Valve plate	1			



# OPERATION MANUAL

## Remote Controller

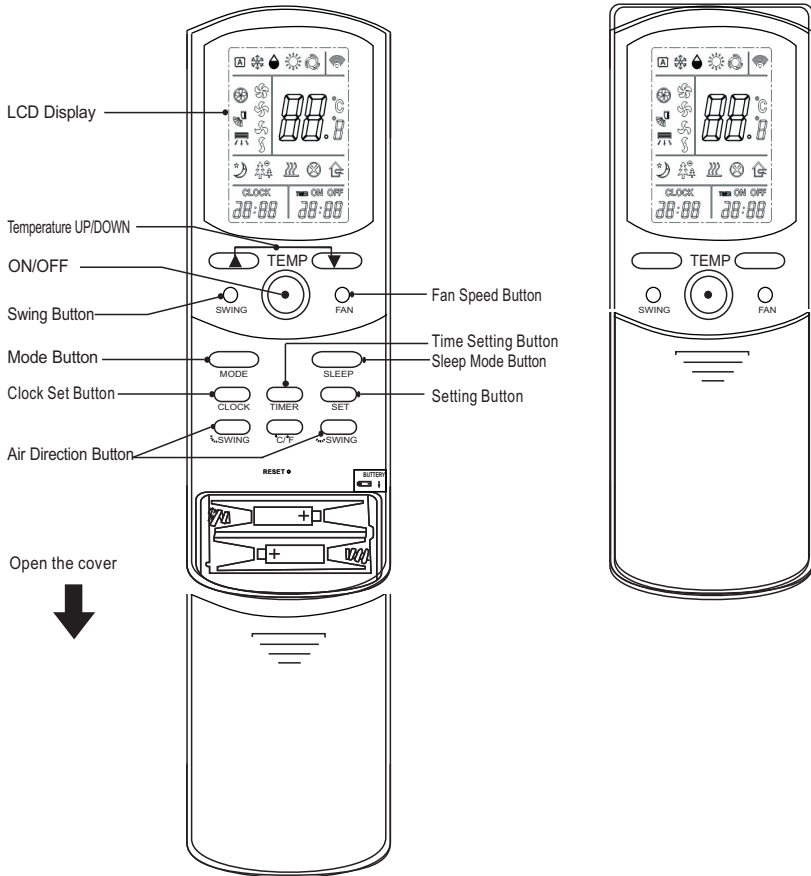

# OPERATION MANUAL

## Timer Operation (Timer-on/Timer-off)

You can set the timer-on or timer-off before you sleep or go home.

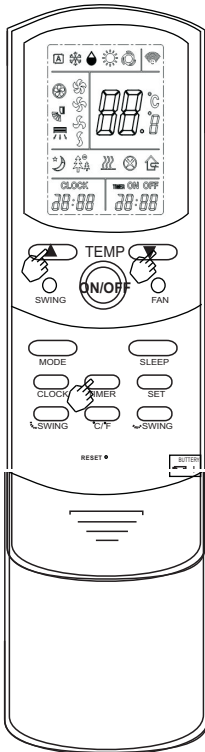

### Setting the Timer-on

- Press **TIMER** button when the unit is running to set the timer-on.
- Press **▲** · **▼** button to set the Hr./Min. Press once, the hour will change with 1 hour, the minute will change with 10 minutes.

### Cancelling the Timer-on

- Press **TIMER** button to cancel the timer-on setting .

### Setting the Timer-off

- Press **TIMER** button when the unit is running to set the timer-off.
- Press **▲** · **▼** button to set the Hr./Min. Press once, the hour will change with 1 hour, the minute will change with 10 minutes.

### Cancelling the Timer-off

- Press **TIMER** button to cancel the timer-off setting .

### Program timer operation

- Time-on and timer-off can be set together, the near setting will take effect first.
- The timer will not be accuracy if you do not adjust the clock on the remote controller.

# OPERATION MANUAL

## Swing Operation ( Vertical Air Direction Adjustment)

Please set the following operation while the air-conditioner is running.

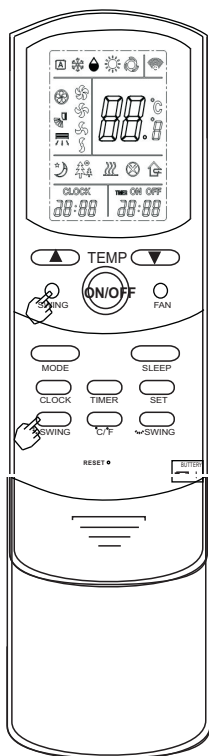

**To start the auto swing operation.**

- Press SWING button.

**To cancel the auto swing operation.**

- Please press SWING button again.
- The auto-swing operation will be cancelled if the SWING button is pressed. please set this auto-swing operation if you want the cool air blow to all over the room.

**⚠ DANGER**

**When adjusting the Right-Left Louvers, it is necessary to stop the Air-Conditioner first and make sure that it stops completely before adjusting the direction.**

## Swing Operation ( Right-Left Air Direction Adjustment)

Move the Right-Left louvers to adjust air flow in the direction you prefer.

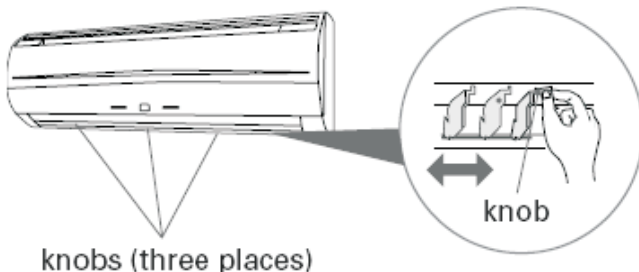

knobs (three places)

# OPERATION MANUAL

## Sleep Operation

Please set the following operation while the air-conditioner is running.

Please set this function when you want a quiet environment to rest.

### To start sleep operation:

- Press SLEEP button, there will have  on the remote controller

### To cancel sleep operation:

- Press SLEEP button again.
- The air flowing sound from the indoor unit becomes lowest immediately.
- In sleep operation, if SLEEP button is pressed by any time, the sleep operation will be cancelled.

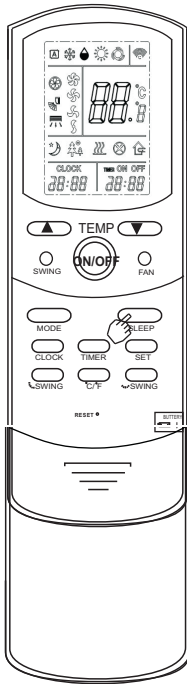

### During Heating operation :

When the SLEEP timer is set, the thermostat setting is automatically lowered 1°C ( 2 °F) every thirty minutes. When the thermostat has been lowered a total of 4 °C ( 8 °F), the thermostat setting at that time is maintained until the set time has elapsed, at which time the air conditioner automatically turns off.

### During Cooling/Dry operation:

When the SLEEP timer is set, the thermostat setting is automatically raised 1°C ( 2 °F) every sixty minutes. When the thermostat has been raised a total of 2°C ( 4 °F) , the thermostat setting at that time is maintained until the set time has elapsed, at which time the air conditioner automatically turns off.



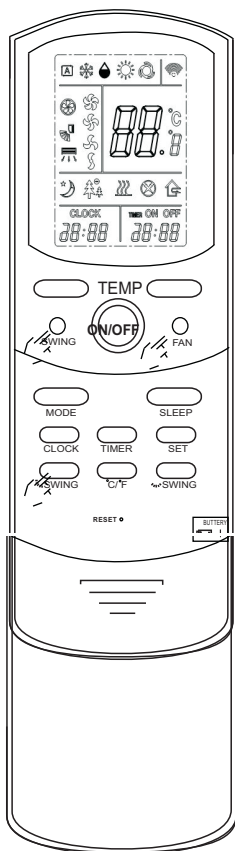

# OPERATION MANUAL

## Fan Speed and Air Flow Direction Adjustment

Select the fan speed and air direction you like.



- Please press FAN to change the fan speed.

When pressed once, the fan speed will be changed in the following sequence: →  
 (Low) →  (Mid) →  (High) →  (Auto)

- Please set the fan speed to high speed if you want to cool down the whole room quickly.
- If you are annoyed at the running sound when you sleep, please set the sleep operation for low speed. (See Page 13)

- Please press SWING button to change the air flow direction.

When pressed once, the up-down air direction will be changed as the following sequence: - (1) → / (2) → / (3) → / (4) → ↓ (5) →  (Auto)

The advised range of the up-down air direction.

Usually you can use  (AUTO)  
 When adjustment, - (1) / (2) place can be set at cooling or dehumidify mode, / (3) to ↓ (5) place can be set at heating pump mode.

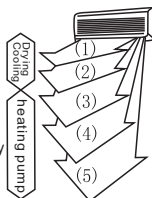

### CAUTION

- The air direction will automatically become horizontal when the air-conditioner run at drying or cooling mode for a hour with / (4) or ↓ (5) place.
- Please use remote controller to adjust the up-down air direction. Do not adjust the up-down louver with the hand to avoid the fault.
- The louver will be set to - (1) automatically if the blowout air temperature is too low or the machine is defrosting under heat-pump unit.

# OPERATION MANUAL

## Select the Mode (Cooling-Dehumidifying-Heating-Ventilation)

Select the mode, and you can adjust the temp. or air direction.

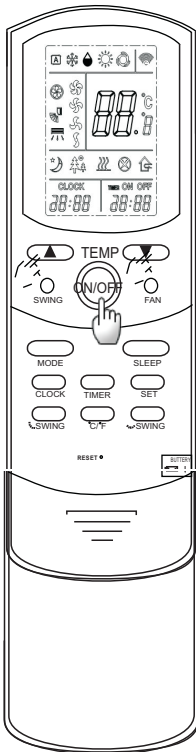

### Caution:

If the doors/windows of the room not well closed, the ambient temperature too hot or too cold, then the room temperature will not reach the setting temperature.

## Select "Auto-Cooling-Dehumidifying-Heating"

- press ON/OFF button.
- Please MODE to select the running mode.

Press once, the mode change as the sequence: Auto - Cooling - Dehumidifying - Heating (only for heating pump type) - Ventilation.



### Need to stop

- Press the ON/OFF button again.  
If you have set the mode, the next time you press ON/OFF button, the machine will run as before.

### Need to change the temperature.

- Want to lower the temperature, please press the DOWN button once, it will lower 1°C/1°F.
- Want to upper the temperature, please press the UP button once, it will upper 1°C/1°F.

**Heating operation** (only for heating pump type)

- When the machine works hard with low outdoor ambient temperature, the outdoor fan motor will stop, and the condenser will defrost for a while, it is not a problem.

**Dehumidifying operation**

- The temperature can be set automatically, not be changed. The machine works at the temperature lower the room temperature a little.

# OPERATION MANUAL

## PREPARING FOR OPERATION

### Remote controller (setting clock)

Never mix new and used batteries, or batteries of different types. Batteries should last about one year under normal use.

- 1 Open the rear cover, put the batteries in.

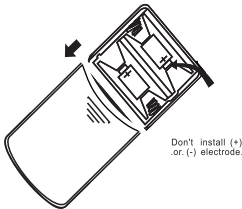

- 2 Press the RESET button.

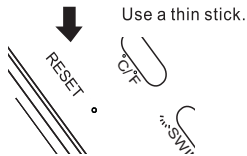

After change batteries, you must reset. If no reset, it maybe operate wrong.

- 3 Press the CLOCK button.

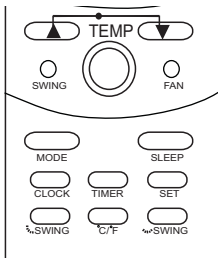

- 4 Press the UP ▲ button for HR. and the DOWN ▼ button for MIN. to set the time.

Press UP.▲ Once, the time change one hour.

Press DOWN. ▼ once, the time change one minute.

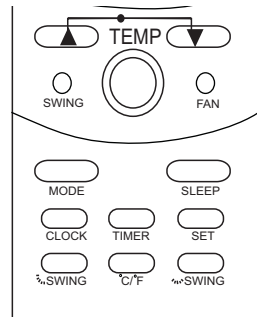

- 5 Press the SET again, the setting time confirm, then closing the rear cover.

#### CAUTION

Take care to prevent infants from accidentally swallowing batteries.

When not using the remote control unit for an extended period, remove the batteries to avoid possible leakage and damage to the unit.

If leaking battery fluid comes in contact with your skin, eyes, or mouth, immediately wash with copious amounts of water, and consult your physician.

Dead batteries should be removed immediately and disposed of properly, either in a battery collection receptacle or to the appropriate authority.

Do not attempt to recharge dry batteries.

# Operation Manual

## When the remote controller can not be used (Emergency Operation)

When the remote controller is lost or cannot be used due to battery run-out, please use the "Emergency" button on the unit to run on the air-conditioner.

### 1 Press the "Emergency" button.

Press the "Emergency" button, the air-conditioner operate with the mode which is changed at a sequence "Cooling → Heating → Stop" or "cooling → stop" (for cooling-only type).

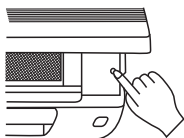

The running content:  
But the temperature adjustment is not effect and the air-conditioner run continuously in the first 30 minutes.

Running content	Cooling	Heating
Set temperature	24°C/76°F	24°C/76°F
Fan speed	(Mid)	(Mid)
Louver	Auto	Auto

### 2 Please press the "Emergency" button if you want to stop the air-conditioner.

Press the "Emergency" button, the air-conditioner operate with the mode which is changed at a sequence "Cooling → Heating → Stop" or "cooling → stop" (for cooling-only type).

## AUTO Restart Function

### In Event of Power Interruption

\* The air conditioner power has been interrupted by a power failure. The air conditioner will then restart automatically in its previous mode when the power is restored.

\* Operated by setting before the power failure.

\* If a power failure occurs during TIMER operation, the timer will be reset and the unit will begin (or stop) operation at the new time setting. In the event that this kind of timer fault occurs the TIMER Indicator Lamp will flash (see Page. 3).

\* Use of other electrical appliances (electric shaver, etc.) or nearby use of a wireless radio transmitter may cause the air conditioner to malfunction. In this event, temporarily disconnect the Power Supply Plug, reconnect it, and then use the Remote Control Unit to resume operation.



# Operation Manual

## CLEANING AND CARE

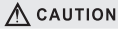

Before cleaning the air conditioner, be sure to turn it off and disconnect the Power. Be sure the Intake Grille (Fig. 1 9) is installed securely.

When removing and replacing the air filters, be sure not to touch the heat exchanger, as personal injury may result.

### Cleaning the Intake Grille

#### 1. Remove the Intake Grille.

- Place your fingers at both lower ends of the grille panel, and lift forward; if the grille seems to catch partway through its movement, continue lifting upward to remove.
- Pull past the intermediate catch and open the Intake Grille wide so that it become horizontal.

Intake Grille

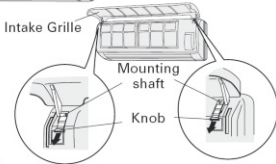
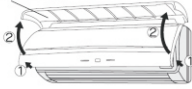

#### 2. Clean with water.

Remove dust with a vacuum cleaner; wipe the unit with warm water, then dry with a clean, soft cloth.

#### 3. Replace the Intake Grille.

- Pull the knobs all the way.
- Hold the grille horizontal and set the left and right mounting shafts into the bearings at the top of the panel.
- Press the place where the arrow on the diagram indicates and close the Intake Grille.

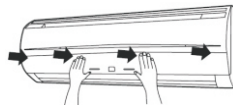
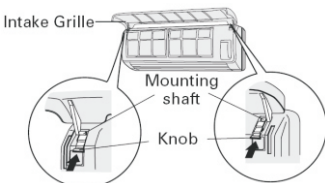
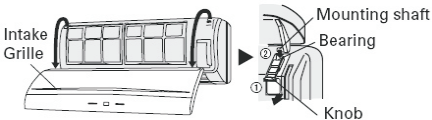

### Cleaning the Air Filter

#### 1. Open the Intake Grille, and remove the air filter.

Lift up the air filter's handle, disconnect the two lower tabs, and pull out.

Air filter handle



Hooks (two places)

- #### 2. Remove dust with a vacuum cleaner or by washing.
- After washing, allow to dry thoroughly in a shaded place.

#### 3. Replace the Air Filter and close the Intake Grille.

- Align the sides of the air filter with the panel, and push in fully, making sure the two lower tabs are returned properly to their holes in the panel.

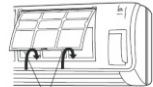

Hooks (two places)

#### 2. Close the Intake Grille.

(For purposes of example, the illustration shows the unit without Intake Grille installed.)

\*Dust can be cleaned from the air filter either with a vacuum cleaner, or by washing the filter in a solution of mild detergent and warm water. If you wash the filter, be sure to allow it to dry thoroughly in a shady place before re-installing.

\*If dirt is allowed to accumulate on the air filter, air flow will be reduced, lowering operating efficiency and increasing noise.

\*During periods of normal use, the Air Filters should be cleaned every two weeks.

\* When used for extended periods, the unit may accumulate dirt inside, reducing its performance. We recommend that the unit be inspected regularly, in addition to your own cleaning and care. For more information, consult authorized service personnel.

\* When cleaning the unit's body, do not use water hotter than 104 °F, harsh abrasive cleansers, or volatile agents like benzene or thinner.

\* Do not expose the unit body to liquid insecticides or hairsprays.

\* When shutting down the unit for one month or more, first allow the fan mode to operate continuously for about one-half day to allow internal parts to dry thoroughly.

# Operation Manual

## CLEANING AND CARE

### Air Cleaning Filter Installation

1. Open the Intake Grille and remove the Air filters.

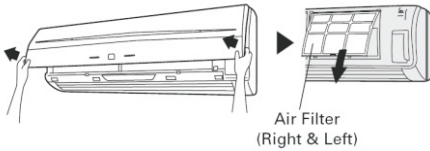

2. Install the Air cleaning filter set (set of 2).
  - a. Set the air cleaning filter into the air cleaning filter frame.

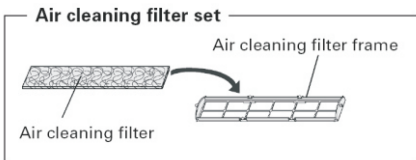

- b. Engage the latch at both ends of the filter with the two hooks at the rear of the air cleaning filter frame.

Hook (2 places at the rear)

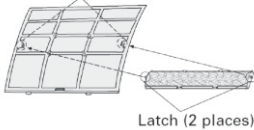

Take care that the air cleaning filter does not project beyond the frame.

- c. Engage the four fixing locations at the top and bottom of the air cleaning filter frame with the hooks of the air filter.



3. Install the two Air filters and close the Intake Grille.

Air Filter (Right & Left)

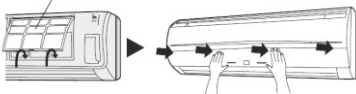

When air cleaning filters are used, the effect will be increased by setting the fan speed to "High".

### Replacing dirty Air cleaning filters

Replace filters with the following components (purchased separately).

POLYPHENOL CATECHIN AIR CLEANING FILTER(optional)  
 Activate carbon filter(optional)

1. Open the Intake Grille and remove the Air filters.

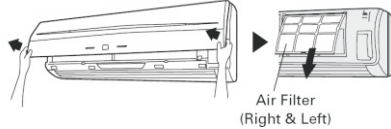

2. Replace them by two new Air cleaning filters.

- a. Remove the old air cleaning filters in reverse order of their installation.
- b. Install in the same way as for installation of the air cleaning filter set.

3. Install the two Air filters and close the Intake Grille.

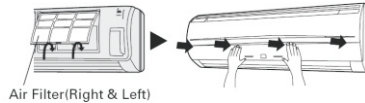

### In regard to the Air Cleaning Filters

#### POLYPHENOL CATECHIN AIR CLEANING FILTER (one sheet)

- \* The Air Cleaning Filters are disposable filters. (They can not be washed and reused.)
- \* For storage of the Air Cleaning Filters, use the filters as soon as possible after the package has been opened. (The air cleaning effect decreases when the filters are left in the opened package)
- \* Generally, the filters should be exchanged about every three months.

**Please buy delicate air cleaning filters (Sold separately) to exchange the used dirty air cleaning filters.**

#### Active carbon filter(two sheets)

- \*The filters should be exchanged about every three months so as to maintain the air cleaning effect.
- \*Filter frame is not a one-off product.

**Please buy delicate Activate carbon filter(Sold separately) when exchanging the filters.**

# Troubleshooting Guide

## On indoor unit central display:

ERROR CODE	ERROR CODE INDICATION	TROUBLE SHOOTING
E 0	OVER CURRENT OR LOW CURRENT PROTECTION	A. Check the voltage of input AC power is within normal range. B. Check DC power voltage on outdoor unit main PCB, if the voltage is lower than 150VDC, then replace the outdoor unit main PCB; if the voltage is higher than 400VDC, then change PFC modular board, or change the inverter modular board.
E 1	EEPROM ERROR	A. Check EEPROM chip on indoor unit PCB is loose, the chip location on 12KBUT/18KBTU model PCB is IC11, on 24KBTU/36KBTU model PCB is IC7; B. After step A, if unit still displays error code E1, change the indoor unit PCB.
E 2	INDOOR UNIT AMBIENT TEMPERATURE SENSOR FAILURE	A. Connection location on indoor unit PCB is: <b>CN11/T1_ROOM</b> for 12kbtu/18kbtu, <b>CN20/ROOM/RT</b> for 24kbtu/36kbtu, replace with new sensor; B. after step A, if unit still displays error code E2, change the indoor unit PCB.
E 3	INDOOR UNIT FAN COIL TEMPERATURE SENSOR FAILURE	A. Connection location on indoor unit PCB is: <b>CN8/T2_PIPE</b> for 12kbtu/18kbtu, <b>CN19/PIPE/PT</b> for 24kbtu/36kbtu, replace with new sensor; B. after step A, if unit still displays error code E3, change the indoor unit PCB.
E 4	OUTDOOR UNIT FAN COIL TEMPERATURE SENSOR FAILURE	A. Connection location on outdoor unit main PCB is: <b>CN15 PO PG PQ</b> for 12kbtu/18kbtu/ 24kbtu/36kbtu, PO is for outdoor ambient temperature sensor, PG is for outdoor fan coil temperature sensor, PQ is for outdoor unit discharge gas temperature sensor. Replace with new sensor; B. after step A, if unit still displays error code E4, change the outdoor unit main PCB.
E 5	POWER OUTPUT TO FAN MOTOR AT INDOOR UNIT PCB NOT DETECTED	Change indoor unit PCB.

# Troubleshooting Guide

E 6	ANTI-FROSTING IN COOLING MODE,ANTI-OVERHEATING IN HEATING MODE	<p>A. Check if indoor unit fan motor is operating;</p> <p>B. Check if unit is in the cooling mode when ambient temperature is too low; or is in the heating mode when ambient temperature is too hot; C. Check if the resistance data of indoor unit fan coil temperature sensor is correct according to resistance data table of sensors in this manual.</p>
E 7	PG FAN MOTOR SPEED MALFUNCTION	<p>A. Check the connection of PG fan motor on the indoor unit PCB at location <b>CN7&amp; CN1</b>, If connection is good, then change the PG fan motor, if unit still displays error code E7, change the indoor unit PCB.</p>
E 8	SIGNAL COMMUNICATION BETWEEN INDOOR AND OUTDOOR UNIT FAILURE	<p>A. Check the wiring sequence between indoor unit and outdoor unit, if wired incorrect this will cause damage to the PCB for both indoor unit and outdoor unit; B. Check the status of LED4 lamp on outdoor unit main PCB, if it's dark or flashing, check the wiring on outdoor unit main PCB, if wiring is correct, change the outdoor unit main PCB; C. if LED4 lamp is lit, change indoor unit PCB; D. If step C does not work, change outdoor unit main PCB.</p>
E 9	INVERTER MODULAR BOARD FAILURE	<p>A. Check the voltage of input AC power is correct; B. Check the wiring on outdoor unit main PCB is correct, or loose; C. If step A &amp; B are passed but unit is still not functional, change the inverter modular board; D. if step C does not work, then change the outdoor unit main PCB.</p>
E b	OUTDOOR UNIT DISCHARGE GAS PIPE TEMPERATURE SENSOR FAILURE	<p>A. Connection location on outdoor unit main PCB is: <b>CN15 PO\PG\PQ</b> for 12kbtu/18kbtu/ 24kbtu/36kbtu, PO is for outdoor ambient temperature sensor, PG is for outdoor fan coil temperature sensor, PQ is for outdoor unit discharge gas temperature sensor. Replace with new sensor; B. after step A, if unit still displays error code Eb, change the outdoor unit main PCB.</p>

# Troubleshooting Guide

E c	OUTDOOR UNIT AMBIENT TEMPERATURE SENSOR FAILURE	A. Connection location on outdoor unit main PCB is: <b>CN15 PO\PG\PQ</b> for 12kbtu/18kbtu/ 24kbtu/36kbtu, PO is for outdoor ambient temperature sensor, PG is for outdoor fan coil temperature sensor, PQ is for outdoor unit discharge gas temperature sensor. Replace with new sensor; B. after step A, if unit still displays error code Ec, change the outdoor unit main PCB.
E E	DISCHARGE GAS TEMPERATURE OR COMPRESSOR TEMPERATURE OVERHEAT PROTECTION	Check that the refrigerant charge is correct, if refrigerant charge is low test system for leaks.
E F	OUTDOOR CONDENSER OVERHEAT IN COOLING MODE	A. Check outdoor unit fan motor is operating; B. Checking if unit is in the cooling mode while ambient temperature is above the system operating range; C. Check outdoor unit fan coil temperature.
P 1	SIGNAL COMMUNICATION BETWEEN OUTDOOR UNIT MAIN PCB AND INVERTER MODULAR BOARD	A. Check the wiring on outdoor unit main PCB is correct or loose; B. If step A is passed, then change outdoor unit main PCB; C. If step A does not pass, change outdoor unit inverter modular board.
P 3	PROTECTION OF OUTDOOR AMBIENT TEMPERATURE TOO LOW	A. Check if outdoor ambient temperature is far below the system operating range, outdoor unit ambient temperature sensor can not touch the outdoor unit fan coil; B. If outdoor low ambient temperature is still within allowance, test or replace the outdoor ambient temperature sensor; C. If step B does not work and unit still has error code P3 displayed, change the outdoor unit main PCB.

# Troubleshooting Guide

---

On outdoor unit main PCB there are 4 LED lamps, one for power supply and 3 for operational status indication and/or ERROR CODE display.

Outdoor unit LED lamps display and error code indication:

LED lamp for power supply is lit when system power is supplied.

LED lamps' color from left to right			ERROR CODE INDICATION
G	Y	R	
X	X	X	Normal operation
○	○	○	Normal Standby
○	X	X	Current protection
☆	X	X	Discharge gas temperature sensor failure
☆	☆	X	Ambient temperature sensor failure
☆	X	☆	Condenser fan coil temperature sensor failure
○	☆	○	Voltage fluctuation protection
X	○	X	IPM modular protection
○	○	X	Compressor temperature protection
X	X	○	Without signal communication between outdoor unit main PCB and outdoor unit inverter modular board for over 2 minutes
☆	☆	○	Compressor driven protection

Remark:

- (1) ○—lighting, ☆—flashing, X— dark.
- (2) flashing frequency: 0.5Hz.

# Operation Manual

## Sensors resistance table

### compressor exhaust temperature sensor resistance

Unit: °C-KΩ (compressor exhaust temperature sensor ) 55K											
t °C	R(KΩ)	AD	t °C	R(KΩ)	AD	t °C	R(KΩ)	AD	t °C	R(KΩ)	AD
-20	542.7	3	20	68.66	26	60	13.59	95	100	3.702	175
-19	511.9	3	21	65.62	28	61	13.11	97	101	3.595	177
-18	483	4	22	62.73	29	62	12.65	99	102	3.492	178
-17	455.9	4	23	59.98	30	63	12.21	101	103	3.392	180
-16	430.5	4	24	57.37	31	64	11.79	103	104	3.296	181
-15	406.7	4	25	54.89	32	65	11.38	106	105	3.203	183
-14	384.3	5	26	52.53	34	66	10.99	108	106	3.113	184
-13	363.3	5	27	50.28	35	67	10.61	110	107	3.025	186
-12	343.6	5	28	48.14	36	68	10.25	112	108	2.941	187
-11	325.1	6	29	46.11	38	69	9.902	114	109	2.86	188
-10	307.7	6	30	44.17	39	70	9.569	117	110	2.781	190
-9	291.3	6	31	42.33	40	71	9.248	119	111	2.704	191
-8	275.9	7	32	40.57	42	72	8.94	121	112	2.63	193
-7	261.4	7	33	38.89	43	73	8.643	123	113	2.559	194
-6	247.8	8	34	37.3	45	74	8.358	125	114	2.489	195
-5	234.9	8	35	35.78	47	75	8.084	127	115	2.422	196
-4	222.8	8	36	34.32	48	76	7.82	129	116	2.357	198
-3	211.4	9	37	32.94	50	77	7.566	132	117	2.294	199
-2	200.7	9	38	31.62	52	78	7.321	134	118	2.233	200
-1	190.5	10	39	30.36	53	79	7.086	136	119	2.174	201
0	180.9	10	40	29.15	55	80	6.859	138	120	2.117	202
1	171.9	11	41	28	57	81	6.641	140	121	2.061	203
2	163.3	12	42	26.9	59	82	6.43	142	122	2.007	204
3	155.2	12	43	25.86	60	83	6.228	144	123	1.955	206
4	147.6	13	44	24.85	62	84	6.033	146	124	1.905	207
5	140.4	13	45	23.89	64	85	5.844	148	125	1.856	208
6	133.5	14	46	22.89	66	86	5.663	150	126	1.808	209
7	127.1	15	47	22.1	68	87	5.488	152	127	1.762	210
8	121	15	48	21.26	70	88	5.32	154	128	1.717	211
9	115.2	16	49	20.46	72	89	5.157	156	129	1.674	211
10	109.8	17	50	19.69	74	90	5	157	130	1.632	212
11	104.6	18	51	18.96	76	91	4.849	159			256
12	99.69	19	52	18.26	78	92	4.703	161			256
13	95.05	20	53	17.58	80	93	4.562	163	B(25/50)=3950K+3%		256
14	90.66	20	54	16.94	82	94	4.426	165			256
15	86.49	21	55	16.32	84	95	4.294	167			256
16	82.54	22	56	15.73	86	96	4.167	168			256
17	78.79	23	57	15.16	88	97	4.045	170	R(90 °C)=5KΩ+3%		256
18	75.24	24	58	14.62	90	98	3.927	172			256
19	71.86	25	59	14.09	93	99	3.812	173			256

# Operation Manual

Sensors resistance table 2

ambient/Indoor/outdoor pipe sensor resistance

Unit: $^{\circ}\text{C}-\text{K}\Omega$ (ambient/Indoor/outdoor pipe sensor)											
T	R	AD	T	R	AD	T	R	AD	T	R	AD
-20	115.266	16	20	12.6431	99	60	2.35774	197	100	0.62973	236
-19	108.146	17	21	12.0561	102	61	2.27249	198	101	0.61148	237
-18	101.517	18	22	11.5	105	62	2.19073	200	102	0.59386	237
-17	96.3423	19	23	10.9731	107	63	2.11241	202	103	0.57683	237
-16	89.5865	21	24	10.4736	110	64	2.03732	203	104	0.56038	238
-15	84.219	22	25	10	113	65	1.96532	205	105	0.54448	238
-14	79.311	23	26	9.55074	116	66	1.89627	206	106	0.52912	239
-13	74.536	24	27	9.12445	119	67	1.83003	207	107	0.51426	239
-12	70.1698	26	28	8.71983	122	68	1.76647	209	108	0.49989	240
-11	66.0898	27	29	8.33566	125	69	1.70547	210	109	0.486	240
-10	62.2756	29	30	7.97078	128	70	1.64691	211	110	0.47256	240
-9	58.7079	30	31	7.62411	131	71	1.59068	212	111	0.45957	241
-8	56.3694	31	32	7.29464	133	72	1.53668	214	112	0.44699	241
-7	52.2438	34	33	6.98142	136	73	1.48481	215	113	0.43482	241
-6	49.3161	35	34	6.68355	139	74	1.43498	216	114	0.42304	242
-5	46.5725	37	35	6.40021	142	75	1.38703	217	115	0.41164	242
-4	44	39	36	6.13059	144	76	1.34105	218	116	0.4006	242
-3	41.5878	41	37	5.87359	147	77	1.29078	219	117	0.38991	243
-2	39.8239	42	38	5.62961	150	78	1.25423	220	118	0.37956	243
-1	37.1988	45	39	5.39689	152	79	1.2133	221	119	0.36954	243
0	35.2024	47	40	5.17519	155	80	1.17393	222	120	0.35982	244
1	33.3269	49	41	4.96392	157	81	1.13604	223	121	0.35042	244
2	31.5635	51	42	4.76253	160	82	1.09958	224	122	0.3413	244
3	29.9058	54	43	4.5705	162	83	1.06448	225	123	0.33246	244
4	28.3459	56	44	4.38736	165	84	1.03069	226	124	0.3239	245
5	26.8778	58	45	4.21263	167	85	0.99815	226	125	0.31559	245
6	25.4954	61	46	4.04589	169	86	0.96681	227	126	0.30754	245
7	24.1932	63	47	3.88673	172	87	0.93662	228	127	0.29974	245
8	22.5662	67	48	3.73476	174	88	0.90753	229	128	0.29216	246
9	21.8094	68	49	3.58962	176	89	0.8795	229	129	0.28482	246
10	20.7184	71	50	3.45097	178	90	0.85248	230	130	0.2777	246
11	19.6891	74	51	3.31847	180	91	0.82643	231	131	0.27078	246
12	18.7177	76	52	3.19183	182	92	0.80132	231	132	0.26408	246
13	17.8005	79	53	3.07075	184	93	0.77709	232	133	0.25757	247
14	16.9341	82	54	2.95896	186	94	0.75373	233	134	0.25125	247
15	16.1156	85	55	2.84421	188	95	0.73119	233	135	0.24512	247
16	15.3418	87	56	2.73823	190	96	0.70944	234	136	0.23916	247
17	14.6181	90	57	2.63682	192	97	0.68844	234	137	0.23338	247
18	13.918	93	58	2.53973	193	98	0.66818	235	138	0.22776	247
19	13.2631	96	59	2.44677	195	99	0.64862	236	139	0.22231	248



# Operation Manual

---

## WIRING FOR AUXILIARY THERMOSTAT

