

QUALIFIED TO  
**NEMA 410**  
STANDARDS

**IR** IN-RUSH  
CAPABILITY

**DR** DIMMING RELAY  
OPTION AVAILABLE



### DESCRIPTION

The IOTA **IIS-375-LED** is a UL Listed stand-alone sine wave output inverter designed to provide power to designated emergency lighting fixtures. In a power loss situation, the IOTA **IIS-375-LED** will supply the full **375W** of power from the onboard battery supply. The IOTA **IIS-375-LED** is specifically designed for LED applications and will prevent shutdown caused by inrush currents of LED drivers without de-rating load size from the full rated output. The **IIS-375-LED** is ideal for applications requiring an emergency source for lighting arrangements utilizing multiple LED fixture types, and will automatically run switched, normally-on, or normally-off designated emergency fixtures. The **IIS-375-LED** is available in a surface mount housing and comes with a three-year warranty and seven-year pro-rata battery warranty.

### SPECIFICATIONS

Input Voltage .....	(Dual) 120/277V, 60Hz
Input Rating (bulk) .....	500 Watts
Output Voltage .....	(Dual) 120/277V, 60Hz
Output Power .....	375 Watts per NEMA 410 (@ .9 leading to .9 lagging PF)
Lamps Operated .....	LED
Transfer Time .....	less than 1 second
Emergency Operation .....	90 minutes
Voltage Regulation (emergency) .....	+/- 2% @ 15% to 110% load
Frequency Regulation (emergency) .....	+/- .5%
Load Power Factor Range .....	.9 leading to .9 lagging
Operating Temp .....	20° to 30° C
Battery .....	Valve Regulated Lead Acid (VRLA)
Weight .....	114 lbs.
Approval .....	UL 924 Listed



### DIMENSIONS

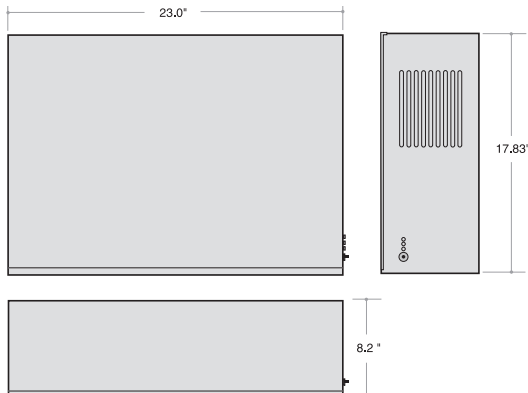

### LOAD CAPABILITY

375 Watts

### FIXTURE TYPES

LED

### PRODUCT ADVANTAGES

- **Inrush accommodation allows operation of multiple LED fixtures with no circuit de-rating**
- **Full light output**
- **Also available with Dimming Relays for 0-10V dimming applications**

### FEATURES

- Emergency lighting supplied from one convenient source
- Pure sine wave output
- Includes momentary contact test switch, yellow ready indicator, green inverter-on indicator, and red charging indicator
- Dual voltage 120/277 60Hz
- High efficiency pure sine wave inverter
- Variable-rate, temperature-compensated charger
- Valve Regulated Lead Acid (VRLA) battery provides long life and is maintenance free
- Line voltage allows for remote mounting of emergency fixtures at distances up to 1000 feet
- Resettable output circuit breaker provides protection against circuit overload
- Low Battery Voltage Disconnect and Line Latch Protection
- Allows for emergency operation of switched or unswitched fixtures
- Meets or exceeds all National Electrical Code and Life Safety Code Emergency Lighting Requirements
- Durable 16-gauge steel housing design with white semi-gloss powder-coat paint finish
- 3/7 Pro-Rata Warranty



# IIS-375-LED

375W SURFACE MOUNT UNIT INVERTER SYSTEM

## ORDERING GUIDE

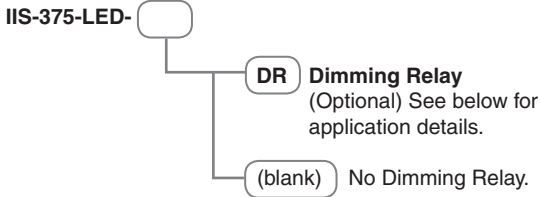

## COMPONENTS

- High-efficiency pure sine wave inverter
- Variable-rate, temperature-compensated charger
- 12V maintenance-free Valve Regulated Lead Acid (VRLA) battery

## CONSTRUCTION

- 16-gauge steel housing

## IIS-375-LED SAMPLE SPECIFICATION

Emergency lighting shall be provided by inverter unit equipment designed to operate designated LED fixtures on emergency power at their full nominal lumen rating during the full 90 minute emergency discharge cycle. System output will be rated at full 375 watts for 90 minutes and provided with an output circuit breaker for protection of overload or load fault conditions. The unit shall be able to accommodate cumulative inrush of the LED load without de-rating of the circuit from the full-rated output of the unit. The system's voltage rating shall be field selectable 120 or 277 VAC input/output.

The inverter unit shall allow for connected emergency fixture(s) to be normally on, normally off, switched or dimmed without affecting lamp operation during a power failure. Upon utility power loss, the inverter unit shall operate the load at 100% of its full rated output regardless of the local switch position, and will provide power to emergency fixtures at distances of up to 1000 feet.

The housing shall be designed for surface mount installation requirements and manufactured using 16-gauge steel with a white hammer semi-gloss scratch-resistant baked-on powder coat paint finish.

The unit's electronics shall include a self-contained inverter section with a fully automatic, thermal-compensating variable-rate battery charger, AC lockout feature, low battery voltage disconnect, DC overload, short circuit and brownout protection as standard. The unit shall utilize a sealed lead calcium battery with a 10-year design life. The inverter system shall be UL 924 Listed and labeled. The unit shall be covered under a 3-year warranty on the electronics and battery and a 7-year pro-rata warranty on the battery. It shall meet or exceed the requirements of UL 924, NFPA 101 Life Safety Code, NFPA 70 National Electrical Code, OSHA and State and Local codes.

The inverter unit shall be IOTA model **IIS-375-LED**.

## TYPICAL WIRING

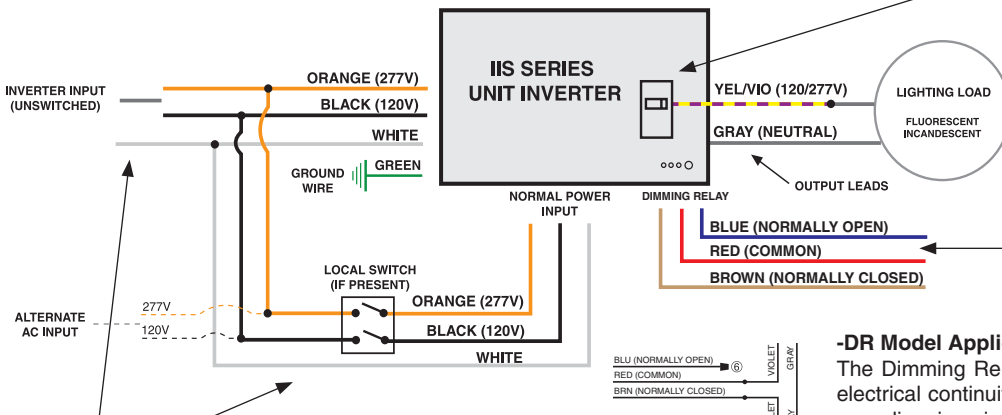

### Internal Circuit Breaker

The internal circuit breaker protects the inverter from overload on the output side of the unit. Internally, the appropriate voltage lead is selected for connection to the line side of the circuit breaker and the designated emergency load connects to the single Yellow/Violet 120/277V hot lead.



### Input Leads

The IIS Inverter utilizes two sets of input leads: one to provide unswitched power to the inverter system and a second to serve as a normal power input to the lighting load. Any switch for the designated emergency circuit will be present on the Normal Power Input leads. For Emergency Operation Only applications, the Normal Input leads are not needed and would remain disconnected and capped.

### -DR Model Application 1 - Dimmer Bypass

The Dimming Relay contacts (on -DR models only) provide electrical continuity during normal power conditions allowing your dimming signal to operate the luminaire in the desired, dimmed state. When the inverter transfers into the emergency mode, the dimming relay contacts electrically open the 0-10 dimming reference signal forcing the luminaire to operate at full lumen output regardless of dimmer setting.

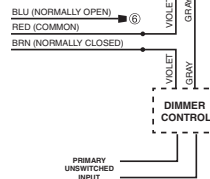

### -DR Model Application 2 - EM Dimming Signal

The Dimming Relay contacts (on -DR models only) are electrically open during normal power conditions allowing your dimming signal to operate the luminaire in the desired, dimmed state. When the inverter transfers into the emergency mode, the dimming relay contacts electrically short the 0-10 dimming reference signal forcing the luminaire to operate at a reduced lumen output setting based on the dimmable driver being used. Verify operating results of the luminaire with the 0-10 volt reference signal shorted to assure the application and mounting height produce code-compliant egress lighting.

