

# 6" CAN RETROFIT KIT 12W

TITANIUM LED SERIES 3.0



Can be used for  
**T24 2008**  
California Title 24  
High Efficacy  
Compliant

PRO



12W REPLACES



**75W Inc.**

80% Energy Savings

**\$204 Savings per lamp\***

- ⌚ Fixture takes just minutes to install
- ☺ Comfortable diffused light
- ⌚ Smooth dimming with existing dimmers
- 🏠 Compatible with most 6" housing
- 📋 Meets Title 24 installation standards
- 🔌 GU24 connector available\*\*

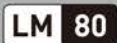

## RETURN ON INVESTMENT

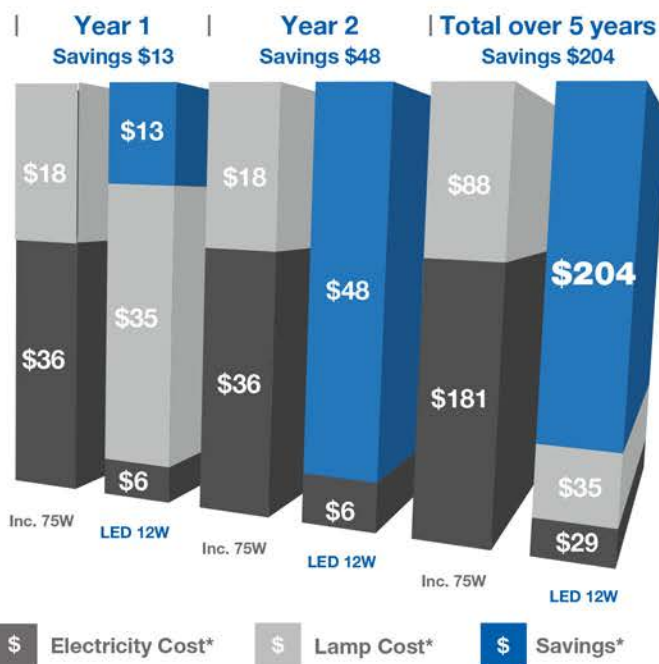

The initial investment of changing a 75W incandescent BR30 lamp to a 12W GREEN CREATIVE lighting solution will take less than 10 months to recover from electricity cost savings.

Following the payback period, the lamp will save \$48 annually throughout the lifetime of the product. Over a 5 year period, each replaced lamp will save \$204 in lighting costs and 1380kW of electricity, equivalent to 0.97 metric tons of CO<sub>2</sub> or the amount of carbon sequestered by 25 trees over 10 years\*.

The monthly cost of waiting before changing to a GREEN CREATIVE energy efficient lighting solution is \$3.99 per lamp.

Furthermore, GREEN CREATIVE lamps are maintenance free with 35,000 hour lifetimes providing additional savings not taken into account in this model.

\*Model assumes Price of Electricity is \$0.11 / kWh (energy costs vary depending on region), Lamp Usage is 12 hours / day (4,380 hours / year), Price of 75W incandescent is \$4 with 1000 hour lifetime, GREEN CREATIVE 12W LED is \$35 with 35,000 hour lifetime. CO<sub>2</sub> emission and tree equivalence based on E.P.A (Environmental Protection Agency) website.

Lighting facts Per Bulb, **Brightness** 800, 750 lumens  
**Estimated Yearly Energy Cost** \$1.45  
 (Based on 3 hrs/day, 11 ¢/kWh. Cost depends on rates and use)  
**Life** 32 years (Based on 3 hrs/day), **Energy Used** 12 watts  
**Light Appearance** 3000K, 2700K

## EASY INSTALLATION

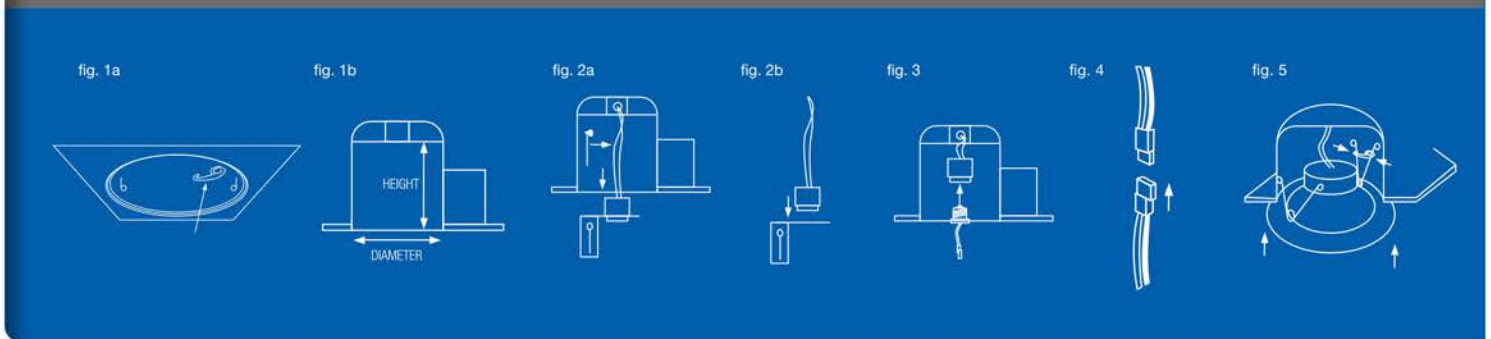

### INCANDESCENT HOUSING INSTALLATION

- Step 1. Make sure the **POWER IS TURNED OFF** at the source to the recessed housing inside which you are installing the product.
- Step 2. Once power has been turned off, remove existing trim and bulb.
- Step 3. Unscrew the lamp socket mounting bracket inside the recessed housing (fig. 2a). Unclip the lamp socket from the bracket and remove the bracket (fig. 2b).
- Step 4. Screw Edison base adaptor into the socket (fig. 3) Connect the female connector of the retrofit kit to the male connector of the socket adaptor (fig. 4)
- Step 5. Squeeze the springs of the retrofit kit and insert them inside the housing retaining bracket (fig. 5). Carefully tuck all the wire inside the can and gently push retrofit kit up flush to ceiling surface.

### LED HOUSING INSTALLATION

- Step 1. Connect the female connector of the retrofit kit to the male connector of the LED housing (fig.4) and then proceed to Step 5 on the left.

### HOUSING COMPATIBILITY

Compatible with most standard 6" insulated and non-insulated housings that have spring retaining brackets inside the can (fig. 1a). Compatibility of housing may be determined by measurement of the housing as detailed in fig. 1b where diameter should be 5.75" to 6.5" and Height Min. 6.5".

## SPECIFICATIONS

Product Model	40696 12DL6G3DIM/830	40695 12DL6G3DIM/827
Type	6" can retrofit kit	6" can retrofit kit
Base	E26 (GU24 optional**)	E26 (GU24 optional**)
Power (W)	12	12
Voltage - Frequency	120V 60Hz	120V 60Hz
Color Temp. (ANSI)	Warm White 3000K	Warm White 2700K
CRI (Ra)	82	82
Typical lumens (lm)	800	750
Efficacy (LPW)	67	63
Dimmable	Yes***	Yes***
Housing compatibility	Most 6" housing	Most 6" housing
Power Factor	0.9	0.9
Rated Lifetime - L70 (hrs.)	35,000	35,000
Dia. x MOL	7.24"x3.98" (184x101 mm)	7.24"x3.98" (184x101 mm)
Weight (lb. / g)	0.90lb / 410g	0.90lb / 410g

\*\* GU24 connector can be ordered separately. Ref. 09-GU24

\*\*\* List of tested dimmer switches available on website

\*\*\*\* Suitable for damp locations. Not for use where directly exposed to weather or water