

# UDLL Series

## Low Profile Dual Basket

### INTENDED USE

Low profile dual basket is ideal for shallow plenum spaces. Specification grade, direct/indirect dual diffuser luminaire provides smooth and uniform ambient lighting for all commercial and industrial buildings with recessed configurations. Reflected light from matte surface proved a softened “sky light” appearance to the modern office environment. LED version provides enhanced light performance, energy savings and maintenance.

### MATERIALS & FEATURES

- Direct/indirect mimics “sky light” appearance
- Matte white reflective surfaces for soft, uniform light distribution
- For use in recessed inverted T-Bar or grid ceilings
- Every fixture is individually tested
- ETL listed for damp locations
- 5 year warranty

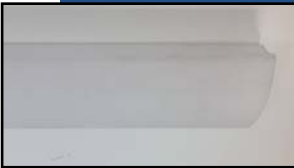

Specially designed lens (LL) for LED Array to provide enhanced light transmission while minimizing glare and LED diode shadows.

### SPECIFICATIONS

Housing is die-formed and embossed code 22 gauge steel. Luminaire body finish is high reflectance baked white enamel, with matte white reflectors. Wiring knockouts are provided on the back of housing. Listed by and bears ETL label. Driver is 350MA suitable for 120V - 277V.

### ORDERING INFORMATION

Part	Output	Driver	Color	Listings
UDLL22L44W3025L40K	3389 Lumens	0-10V Dimming	4000K	ETL
UDLL24L88W6050L40K	5041 Lumens	0-10V Dimming	4000K	ETL

Add “SH” to prefix for surface mount with shroud.

**DLC Listed**

Catalog Number:
Notes:

# UDLL Series

## Low Profile Dual Basket

### DIMENSIONS

TOP VIEW 2x2

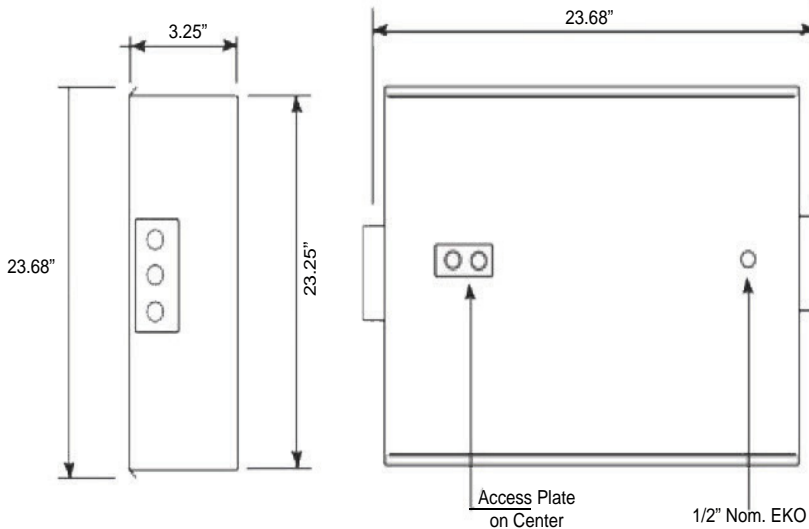

TOP VIEW 2x4

