

### Specifications:

Lamp Type	Three 6V, 9W 939 Type Lamps
Emergency Operation	90 minutes

### Listings & Certifications:



### Model: FHNY30



### Mechanical Data:

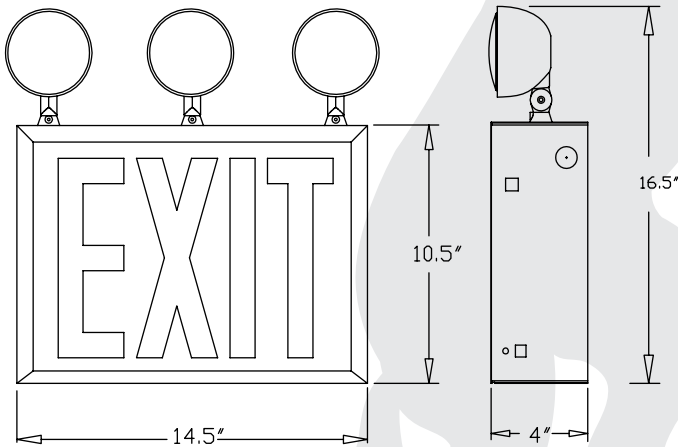

### Standard Features:

- Sealed Push-to-test Switch
- LED Charge Indicator
- Maintenance Free, 6V Sealed Lead-Acid Battery
- Dual Voltage 120V/277V
- Universal KO Chevrons
- Three Fully Adjustable Glare-Free Heads, Constructed of Impact Resistant Thermoplastic
- Single Face Red Letters
- White Powder Coat Finish
- Heavy Duty 20 Gauge Construction
- Sealed AC Ready Light
- New York City Approved

### Ordering Information:

Base Model No.
FHNY30