

Mechanical Data:

4.25" X 4.75" Core

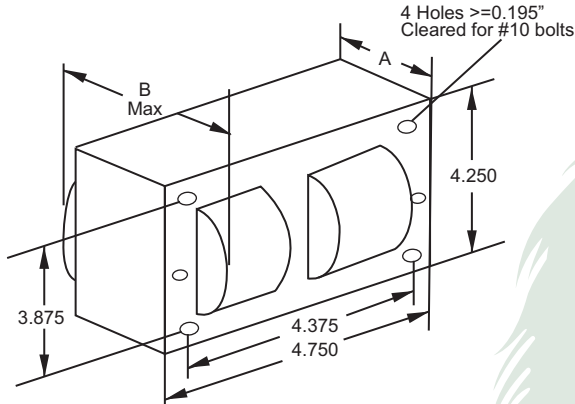

DIMENSION A
DIMENSION B
TOTAL WEIGHT
LEAD LENGTHS

2.32 IN
4.26 IN
11.4 LBS
12 IN

Capacitor: HHMHDCAP5400 (Dry Type)

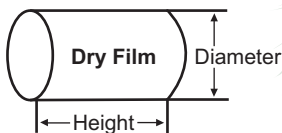

Diameter 1.78"
Height 3.15"

24 μ F 360V

Electrical Data:

INPUT VOLTS
MIN. STARTING TEMP
POWER FACTOR (>%)
ANSI CODE
CIRCUIT TYPE
WATTS INPUT
NOM OPEN CIRCUIT VOLTAGE (V)
RECOMMENDED FUSE (AMPS)
REGULATION
LINE VOLTS
LAMP WATTS
INPUT VOLTAGE AT LAMP DROPOUT
LINE CURRENT (AMPS)
OPERATING
OPEN CIRCUIT
STARTING
UL TEMPERATURE RATINGS
180° CLASS H
COIL TEMPERATURE CODE
CAPACITOR REQUIREMENT
MFD
MIN VOLT
IGNITOR
PART NUMBER
MAX DIST TO LAMP
HIGH POTENTIAL TEST (V)
OPEN CIRCUIT VOLTAGE TEST (VOLTS)
SHORT CIRCUIT CURRENT TEST (AMPS)
COIL MATERIAL

120	208	240	277	480		
-20°F/-30°C						
90%						
400W, M-59						
CWA						
452						
300						
12	8	6	6	4		
+10%						
+10%						
65	110	130	160	270		
4.0	2.3	2.0	1.8	1.0		
2.9	1.7	1.5	1.2	0.7		
2.9	1.7	1.5	1.1	0.7		
B	B	C	C	C		
1029						
24mF						
360V						
N/A						
50FT						
1 MIN: 2000, 1 SEC: 2400						
280 - 330						
SECONDARY	MIN	3.2				
	MAX	5.0				
INPUT	MIN	1.1	0.7	0.6	0.5	0.3
	MAX	3.3	2.0	1.7	1.5	0.9
Cu/Al						

Wiring Diagram:

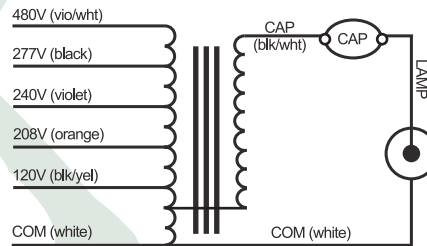

LEAD LENGTH (INCHES):
12

Options:

Basic Ballast Kit includes Ballast, Dry Capacitor, and Mounting Hardware only.
HID Ballast and Lamp Kits also available; please see website www.fulham.com