



SPECIFICATION SHEET :FH3-DUAL-450L
 This Is An Original Product From Fulham Co., Inc

Project _____ Type _____ Model # _____
 Remarks _____

Description: Firehorse Emergency Ballast for use with or without AC ballast designed to add emergency lighting when main AC power is interrupted for minimum of 90 minutes at reduced illumination. The emergency ballast is not intended for general purpose lighting applications.

This Ballast Will Operate Following Lamps.
ONE 9W TO 42W 4-PIN CFL OR **ONE** 18W TO 40W LONG COMPACT OR **ONE** 17W to 40W(2'-4') T8/T10/T12 INCLUDING CIRCLINE OR **ONE** 8W TO 21W T5 FLUORESCENT LAMP AT REDUCED ILLUMINATION (ALL WITHOUT INTEGRAL STARTER)

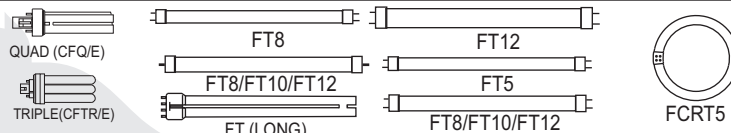

ELECTRICAL DATA

INPUT VOLT: 120V OR 277V ± 10%, 60Hz	
APPROVAL CLASS	UL - LISTED FOR DAMP LOCATION – FACTORY OR FIELD INSTALLATION
CODE COMPLIANCE	MEETS OR EXCEEDS UL924 – N.E.C. AND LSC EMERGENCY OPERATING REQUIREMENT
AC INPUT POWER RATING	2.5 WATTS
AC INPUT CURRENT	280mA
BALLAST TYPE	EMERGENCY
MINIMUM ILLUMINATION TIME	90 MINUTES
RECHARGE TIME	24 HOURS
MAXIMUM INITIAL LIGHT OUTPUT	450 LUMENS
BATTERY TYPE	HIGH TEMPERATURE RECHARGABLE NI-CAD – MAINTENANCE FREE
TEMPERATURE RATING (AMBIENT)	0°C TO 50°C (32°F TO 122°F)
BATTERY VOLTAGE	2.4Vdc
BATTERY CHARGING CURRENT	280mA Max.
BATTERY RATING	9.6W h
MINIMUM BATTERY RATING	4.0Ah
TEST SWITCH	SINGLE POLE
CHARGING INDICATOR LIGHT	LED
CASE TYPE	VANDAL RESISTANT – SEALED
CASE CONSTRUCTION	PAINTED STEEL
CASE PROFILE	9.4”L X 2.4”W X 1.5”H X 8.9” MOUNTING CENTER
CASE WEIGHT	2.8 lbs.
AC BALLAST COMPATIBILITY	ELECTRONIC FLUORESCENT – STANDARD AND DIMMING
LAMP COMPATIBILITY	FLUORESCENT SINGLE/BI-PIN / 4-PIN WITHOUT STARTER
FIXTURE COMPATIBILITY	INDOOR SWITCHED AND UNSWITCHED TYPE
WIRE CONNECTION (STANDARD)	STANDARD WIRE LEADS
LED TEST SWITCH TYPE (STANDARD)	TEST SWITCH & LED INDICATOR

MECHANICAL DATA

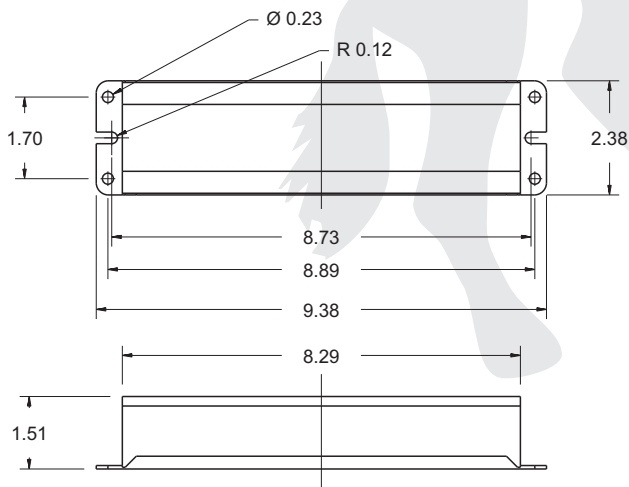

Where : L = Length, W = Width, H = Height all in inches

**TABLE 1
LUMEN OUTPUT CHART**

FH3-DUAL-450L WITHOUT INTEGRAL STARTER	WATTS	BASE TYPE	INITIAL LUMEN OUTPUT	
			1 LAMP	2 LAMPS
T12	20/30	G13/med-bipin	350-425	X
T12	40	G13/med-bipin	450	X
F48T10	110	R17D/REC	350-450	X
T8	17/25/40	G13/med-bipin	325-450	X
T8	32	G13/med-bipin	450	X
T9	20/22/32	G10Q-4	400-450	X
T9	40	G10Q-4	450	X
FT(LONG)	27/24	2G11	400-425	X
FT(LONG)	39/36	2G11	450	X
FT(LONG)	40/30	2G11	400-450	X
T5(CIRCULAR)	22/40	2GX13	400-450	X
T5	14/21	mini-bipin	400-450	X
CFQ	13	G24Q-1	300-350	X
CFQ	18	G24Q-2	400-450	X
CFTR	26/32	GX24Q-3	450	X
CFTR	42	GX24Q-4	450	X

Partial list of lamps operated - contact Fulham Customer Service when referencing alternative lamps - lumen ratings may vary with lamp specifications, light loss, lamp and luminaire maintenance and other utilization factors.

NOTE: WIRING DIAGRAMS SHOWN ON A SEPARATE SHEET

Fulham Co., Inc extends limited warranty only to the original purchaser or to the first user for the period of 2 years from the date of manufacture as indicated and operated under normal conditions of use. For complete terms and conditions, please reference the Fulham Product Catalog (www.fulham.com).

Due to a program of continuous improvement, Fulham reserves the right to make modifications or variations in design or construction to the equipment described.



SPECIFICATION SHEET :FH3-DUAL-450L This Is An Original Product From Fulham Co., Inc

APPLICATION

The **FireHorse** emergency ballast can be used to add emergency lighting with or without an AC ballast and with most fluorescent fixtures without affecting normal fixture operation. The emergency ballast is designed for factory or field installation and can be mounted on top, inside, or remote from the fixture.

If used in an emergency-only fixture, no AC ballast is required. The **FireHorse** emergency ballast is not suitable for use in air handling heated air outlets, outdoor, wet, or hazardous locations. The emergency ballast should not be installed near gas or electric heaters. The **FireHorse** emergency ballast is rated for Indoor Dry/Damp locations and for sealed and gasketed fixtures, including fixtures rated for UL wet locations .

OPERATION

The **FireHorse** emergency ballast is designed to immediately switch to the emergency mode when the primary AC power is interrupted, illuminating one or two lamps at a reduced lumen output for a minimum of 90 minutes. Upon restoration of primary AC power; the **FireHorse** emergency ballast immediately returns to a battery charging mode. The LED indicator light source when illuminated indicates battery is in charge mode when AC power is applied. It is recommended and by code required to test the emergency ballast every 30 days to ensure that the ballast is functioning as evidenced by reduced illumination of one or two lamps when pushing the test switch. It is also recommended a 90 minute discharge test is performed one time every 12 months. Battery requires 24 hours to fully re-charge.

INSTALLATION

The **FireHorse** emergency ballast may be used with either a switched or un-switched fixture. If a switched fixture is used, an un-switched hot lead must be connected to the emergency ballast to ensure the ballast remains in an uninterrupted charge condition while primary AC power source is active. Reference Installation Instructions for appropriate wiring or contact Fulham Customer Service. The **FireHorse** emergency ballast must be fed from the same branch circuit as the AC ballast.

The **FireHorse** emergency ballast may be remote-installed up to half the distance the AC ballast manufacturer recommends for remote mounting the AC ballast from the lamp, or up to 50 feet, whichever is less distance. The remote test switch plate may be mounted within 50 feet of the fixture and is subject to NEC and applicable local electrical code.

Installation is not recommended with fixtures where the ambient temperature may fall below 0° C for extended periods as this may affect the operation of the emergency ballast.

UL and CODE COMPLIANCE

The **FireHorse** emergency ballast has been tested by Underwriters Laboratories in accordance with the standards contained in UL924, "Emergency Lighting and Power Equipment", and is UL approved for factory or field installations. Emergency illumination time meets or exceeds the National Electrical Code (NEC), Life Safety Code (NFPA-LSC) and UL 90 minute requirements.

BATTERY

The **FireHorse** emergency ballast contains a uniquely constructed, high-temperature rechargeable nickel cadmium battery. The battery is sealed within the ballast housing and is not replaceable. The battery must be recycled or disposed of properly and in compliance with federal, state and local regulations.

EMERGENCY ILLUMINATION

Illumination output varies with number of lamps, either 1 or 2 lamps, and lamp wattage requirement. The **FireHorse** model **FH3-DUAL-450L** is designed to produce 300-450 initial emergency lumens output; if model works with 2 lamps the total initial lumens is distributed between the 2 illuminated lamps. Refer to Table 1 for average lumen output for selected lamps.

SPECIFICATION

Emergency lighting shall be provided by using a **FireHorse** emergency ballast with a standard fluorescent fixture equipped with or without an AC ballast. The emergency ballast shall be capable of operating one or two fluorescent lamps as referenced in Table 1. The emergency ballast shall conform to specifications contained in Electrical Data Table and comply with standards set forth by the current NEC. The emergency ballast shall be UL approved for installation on top, inside, or remote from the fixture.

NOTE: USE OF LOW MERCURY, "GREEN" LAMPS

A growing number of fluorescent lamp manufacturers have reduced the level of mercury content in their products. While this is helpful to the environment, the lower mercury content makes the lamp more difficult to start in emergency mode, particularly in a compact fluorescent cold-start emergency-only application without an AC ballast. Please contact Fulham Customer Service for further assistance if needed.



EMERGENCY BALLAST AND AC BALLAST MUST BE FED FROM THE SAME BRANCH CIRCUIT.

TYPICAL SCHEMATICS ONLY. MAY BE USED WITH OTHER BALLASTS. CONSULT THE FACTORY FOR OTHER WIRING DIAGRAMS

WIRING DIAGRAMS FOR 1 LAMP EMERGENCY OPERATION

FOR 1 LAMP FIXTURE

A. INSTANT START BALLAST

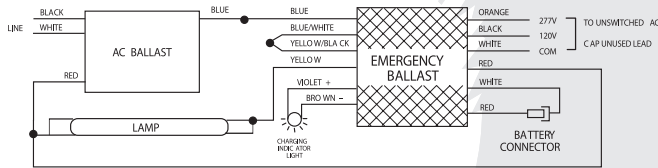

B. RAPID START BALLAST

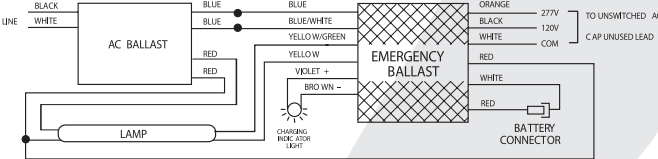

FOR 2 LAMP FIXTURE

A. INSTANT START ELECTRONIC BALLAST

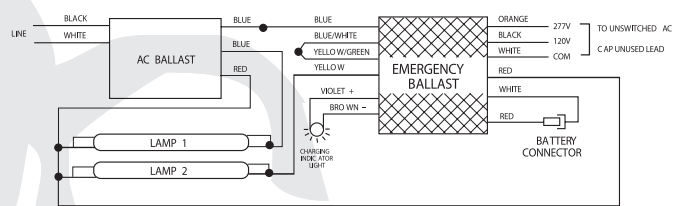

B. RAPID START BALLAST

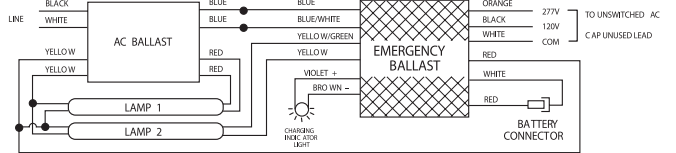

C. CIRCLINE RAPID START BALLAST

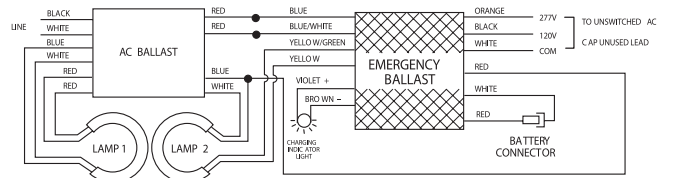

EMERGENCY ONLY

ONE (1) LAMP WITHOUT AC BALLAST

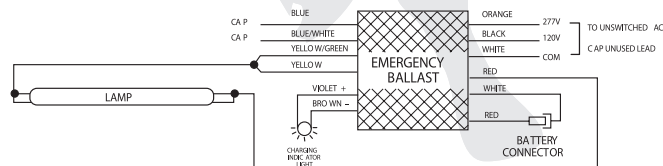

NOTE: YELLOW/GREEN OR YELLOW/BLACK PROVIDED - USE INTERCHANGEABLY



EMERGENCY BALLAST AND AC BALLAST MUST BE FED FROM THE SAME BRANCH CIRCUIT.
TYPICAL SCHEMATICS ONLY. MAY BE USED WITH OTHER BALLASTS. CONSULT THE FACTORY FOR OTHER WIRING DIAGRAMS

WIRING DIAGRAMS FOR 1 LAMP EMERGENCY OPERATION

FOR 3 LAMP FIXTURE

A. RAPID START BALLAST

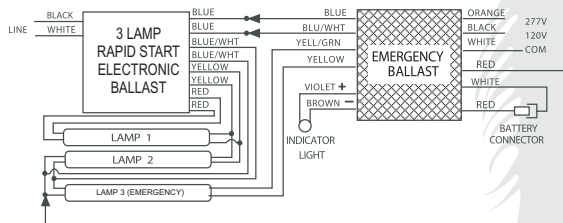

B. INSTANT START BALLAST

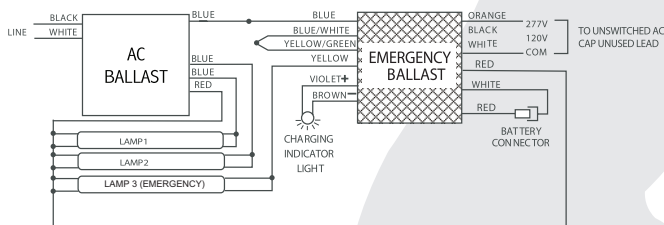

FOR 4 LAMP FIXTURE

C. RAPID START BALLAST

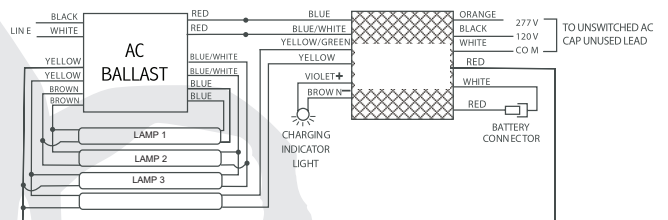

D. INSTANT START BALLAST

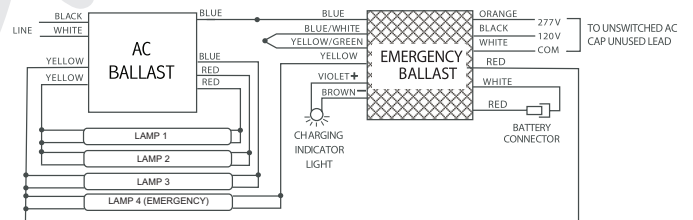

NOTE: YELLOW/GREEN OR YELLOW/BLACK PROVIDED - USE INTERCHANGEABLY

