

CANDLES

STRAIGHT TIP

BENT TIP



SPECIFICATIONS

EQUIVALENT	45 Watt Incandescent
AVERAGE RATED LIFE	25,000 hrs
HOUSING	Glass, Aluminum, Polycarbonate
BASE	Small (E12)
POWER	120V, 60Hz
LENS	ST: Frosted Polycarbonate BT: Frosted Glass
BEAM	320°

BENEFITS

- Up to 83% more efficient than incandescent equivalent
- Longer life and lower maintenance costs
- Dimmable when used with approved dimming switch
- Mercury and Lead free, as well as UV and IR free
- Instant on to full brightness

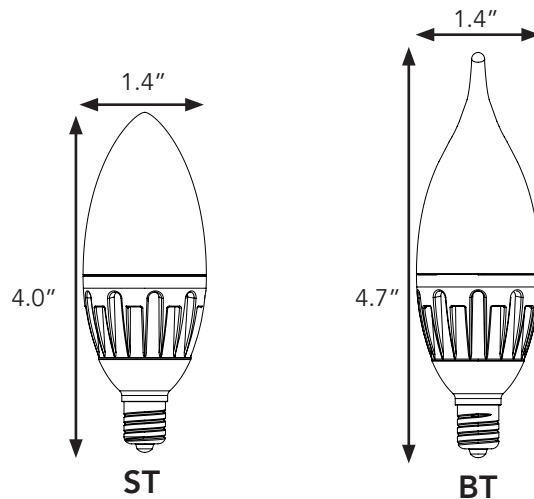

DIMMER COMPATIBILITY*

Lutron: MACL-153M, LGCL-153PLH, TAL06P-C1-K-L, TGCL-153PH, AYCL-153P, DVCL-153P, DVSCCL-153P, SCL-153P, MSCL-OP153M, CTCL-153P, TTCL-100, SELV-300P, DVELV-300P **Cooper:** ASPIRE-9573, DEVINE-DLC03P, SKYE-SLC03P, SAL06P, AAL06-C1-K-L, DAL06P-C1-K-L

*The listed dimmers have been tested and proven to work under limited laboratory conditions. All possible electrical conditions cannot be accurately simulated, and therefore some discrepancy may exist.

APPLICATION INFORMATION

Applications	Market Segments
— Decorative	— Residential
— Chandelier	— Hospitality
— Specialty	— Restaurant

Application Notes

1. Operating temperature range between -20°C and +45°C (-4°F and +113°F)
2. Not for use with emergency light fixtures or exit lights
3. Not for use in totally enclosed fixture
4. Suitable for indoor/damp locations and sheltered outdoor use

This device complies with Part 15 of the FCC rules and has been tested and found to comply with the limits for a Class B digital device. These limits are designed to provide reasonable protection against harmful interference in a residential installation. This equipment uses and can radiate radio frequency energy and, if not installed and used in accordance with the instructions, may cause harmful interference to radio communications. Any changes or modifications not expressly approved by the manufacturer could void the user's authority to operate the equipment.

CERTIFICATIONS



LM79 reports are available upon request.



Based on 12 hours of use per day.

CANDLES

ORDERING INFORMATION

STRAIGHT TIP

Order Code	Part Number	Wattage (W)	Base	Replaces	Voltage (V)	CCT ¹	Typical Lumens ²	CRI ³	Dim	Beam	Weight (lbs)	Case Quantity
K8L6	LED-BST-350-27	6	E12	45W Candle	120	2700	455	80	Yes	320°	0.2	50
K8L7	LED-BST-350-50	6	E12	45W Candle	120	5000	490	82	Yes	320°	0.2	50

BENT TIP

Order Code	Part Number	Wattage (W)	Base	Replaces	Voltage (V)	CCT ¹	Typical Lumens ²	CRI ³	Dim	Beam	Weight (lbs)	Case Quantity
K8L8	LED-BBT-350-27	6	E12	45W Candle	120	2700	430	80	Yes	320°	0.2	50
K8L9	LED-BBT-350-50	6	E12	45W Candle	120	5000	470	81	Yes	320°	0.2	50

1. Thermally stable typical CCT ($\pm 10\%$) 2. Thermally stable typical lumens ($\pm 10\%$) 3. CRI - Color Rendering Index

For the most up-to-date specifications, visit kobielectric.com.



KOBI ELECTRIC

800-505-2106 / kobielectric.com
253 Loy St / Burleson, TX 76028

Specifications are typical values and may change without notification.
©2014 Kobi Electric, Inc. All Rights Reserved

Candles
Rev 1_100614