

CDM

CDM-SA/R 150W/942 UNP



The perfect color rendering and long life of these Ceramic Discharge Metal-halide lamps make them ideal for fiber optics lighting systems in shop displays, decorative lighting and swimming pool illumination.

They can be mounted in color changing projectors.

Product data

• General Characteristics

Cap-Base	Ceramic Cap-Cable
Cap-Base Information	Cable 250mm
Operating Position	any
Main Application	Fiber Optics
Life to 50% failures	6000 hr

• Light Technical Characteristics

Color Code	942
Color Rendering Index	96 Ra8
Color Designation (text)	Cool White
Color Temperature	4200 K
Color Temperature Technical	4000 K
Chromaticity Coordinate X	361 -
Chromaticity Coordinate Y	351 -
Luminous Flux Lamp EM	2300 (min), 2750 (nom) Lm
Luminous Efficacy Lamp EM	19 Lm/W

• Electrical Characteristics

Lamp Wattage	150 W
Lamp Wattage Technical	152 W
Lamp Current	1.8 A

Ignition Supply Voltage	198 (min) V
Dimmable	No

• Luminaire Design Requirements

Pinch Temperature	350 (max) C
Bulb Temperature	650 (max) C

• Product Dimensions

Overall Length C	106 (max) mm
Diameter D	95.3 (max) mm
Cable Length X	280 mm

• Product Data

Order code	928086805303
Full product code	928086805303
Full product name	CDM-SA/R 150W/942 UNP
Order product name	CDM-SA/R 150W/942 UNP/1
Pieces per pack	1
Packing configuration	1
Packs per outerbox	1
Bar code on pack - EAN1	8727900783490
Bar code on outerbox - EAN3	8711500201508
Logistic code(s) - 12NC	928086805303
Net weight per piece	0.192 kg

PHILIPS

sense and simplicity

Dimensional drawing

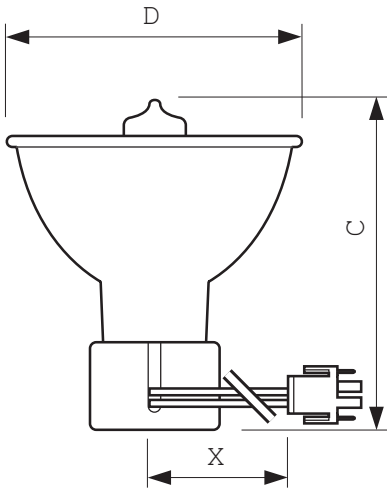

CDM-SA/R 150W

Product	C (Max)	D (Max)	X (Norm)
CDM-SA/R.150W/942	106	95.3	280



Ceramic Cap-Cable

Photometric data

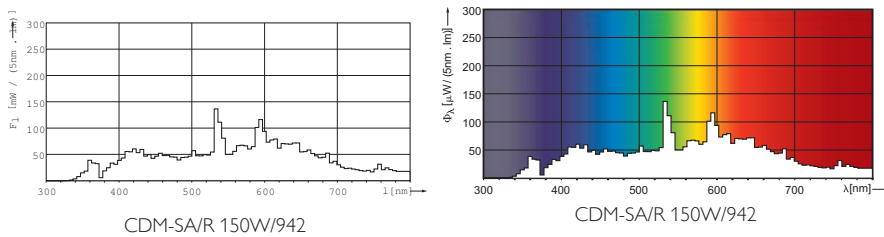

© 2012 Koninklijke Philips Electronics N.V.
All rights reserved.

Specifications are subject to change without notice. Trademarks are the property of Koninklijke Philips Electronics N.V. or their respective owners.

www.philips.com/lighting

2012, August 4
data subject to change