

Model Number:

Accessories:

Type:

Job:

Approvals:

PRODUCT SPECIFICATIONS

CONSTRUCTION

The Trace-lite TL101 Series features a durable, vandal-resistant, injection molded polycarbonate enclosure with an architectural bronze finish. Enclosure is fully sealed and gasketed, and is Wet Location Listed for outdoor use. Enclosure and hardware are corrosion resistant. The TL101 features an internal, anodized aluminum reflector which provides ideal light distribution, and the lamp is protected by a high-impact, UV stabilized polycarbonate prismatic refractor.

LAMPS & BALLASTS

Compact Fluorescent: 4-Pin Triple Tube lamps from 26 to 42 watts, utilizing a GX24-q3 base with an electronic programmed start ballast rated for a minimum operating temperature of -20°C (-4°F) and 120/277VAC input.

120VAC Photocontrol is included standard with all lamp types.

INSTALLATION

The Trace-lite TL101 Series is ideal for mounting to any vertical surface and features a rugged die-cast aluminum mounting plate. Can be wired to a 4" junction box, or surface mounted using the 1/2" NPT conduit entry point.

WARRANTY

Any housing component that fails due to manufacturer's defect is guaranteed for two years from time of shipment. Ballasts, Capacitors, and Ignitors are warranted for one year from time of shipment. Warranty does not apply to damages caused by improper installation, abuse, fire or acts of God. Lamp is not covered by manufacturer's warranty.



The Trace-lite TL101 Series is a small, economical wallpack that is ideal for accent, security, and entry lighting. Perfect for entrance ways, garages, overpasses, tunnels, and alleys.



SPECIFICATIONS ARE SUBJECT TO CHANGE WITHOUT NOTICE

ORDERING INFORMATION

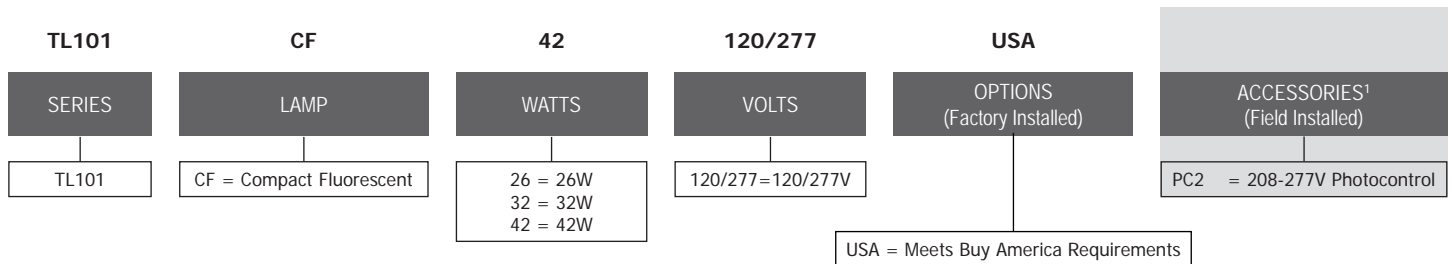

¹ Order as Separate Line Item

SAMPLE PHOTOMETRICS

TL101-CF-42 Mounted at 10'

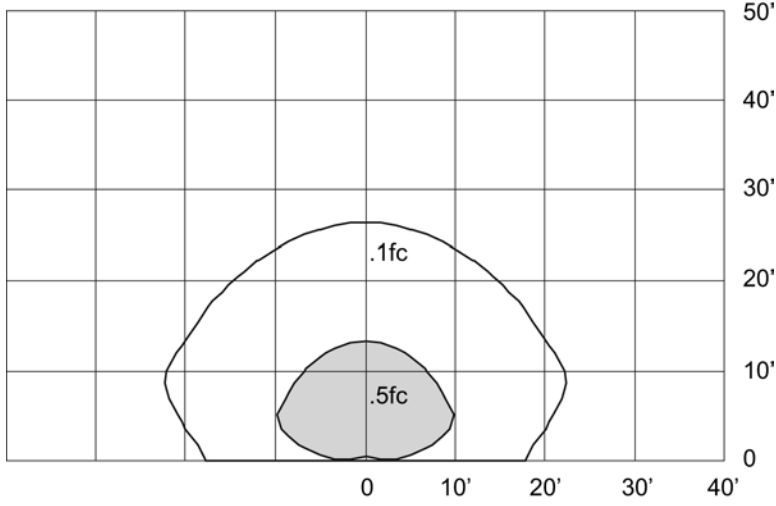

DIMENSIONS

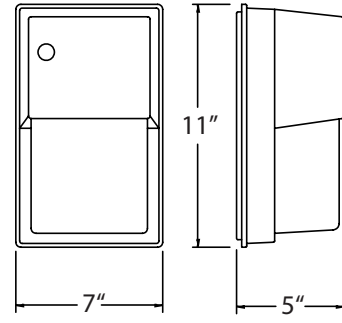

Approximate Weight: 4 lbs.