

Model Number:

Accessories:

Type:

Job:

Approvals:

DESCRIPTION

The TLED-LB series low bay's low profile design combined with a high performance LED light source and superior thermal management makes it an attractive, energy saving choice. Constructed of die formed and welded aluminum, the TLED-LB series design has been engineered to provide a LED low bay luminaire that delivers optimum lumen performance and a very long lamp longevity in an attractive and durable housing. The TLED-LB uses a UV resistant powder coated finish to protect against the elements and is ETL listed for wet locations. Available LED light engines with total system draw of 32, 48, or 64 watts and delivered lumen outputs of 3212, 4716, or 6152 respectively. The TLED-LB provides a energy saving solution to a wide spectrum of situations including, but not limited to low bay lighting applications in schools, office complexes, light commercial facilities, parking garages and retail sales locations.

SPECIFICATIONS

Construction:

A precision die formed aluminum housing features clean architectural lines with ample, integral mounting space for many future accessories, the TLED-LB's most prominent construction features is its integrated thermal management. The housing is fabricated using 1/8" Aluminum plate, which not only provides strength and durability but also acts as a substantial heat sink to allow for optimum performance and durability of the LED light engine without sacrificing design aesthetics or increasing the outside dimensions of the housing. LEDLITElogic heat sinking technology moves heat away from the LEDs by taking advantage of thermal convection dynamic properties and maximizing system performance that delivers up to a 140,000 hour life with 70% lumen maintenance. The TLED-LB is ETL listed for wet locations, and incorporates a UV resistant, long lasting, polyester based powder coated finish.

Optics:

Our TLED-LB series low bay luminaire delivers exceptional light quality, efficiency and light distribution with an optical design that provides a balanced distribution using the 32 LED, 48 LED or 64 LED light engines. The layout of the LED's on the module board and the faceted, optical lens are a second generation design specifically engineered to work together providing light where it is needed in the most efficient way possible setting a global standard for energy efficiency.

Electrical:

A choice of three performance levels are available in the TLED-LB series with LED light engines utilizing either 32, 48, or 64 LEDs, drawing 36 watts, 54 watts, or 71 watts and providing 3212, 4716, or 6152 initial delivered lumens, see chart on Page 2 for complete performance figures. The available LED light engine wattages are powered by constant voltage control drivers and provide up to a 140,000 hour rated life with 70% lumen maintenance, a 4500K to 5000K CCT, and a CRI of ≥ 75 . All drivers are Class 2 power supplies with input voltage range of 120VAC to 277VAC, providing a Class A EMI rating and a high power factor of ≥ 0.90 . The TLED-LB is suitable for operation in -40°C (-40°F) to 40°C (104°F) ambient conditions.

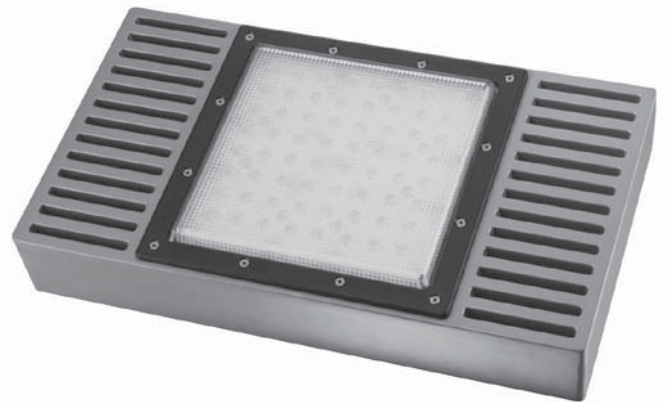
Environmentally Friendly Design:

TLED-LB low bay luminaires consume very little energy and provide long life in comparison to traditional lamp technologies. Our manufacturing process utilizes no hazardous substances such as mercury or lead. The LED-LB is RoHS (Restriction of Hazardous Substances) compliant, 100% recyclable, and provides up to a 60% significant reduction in Kw load as well as reducing carbon emissions.

Installation:

The TLED-LB series can be installed and wired by a single person, and is designed to be pendant mounted using a standard 1/2" threaded downrod (supplied by others).

Testing & Compliance:

The reliability and performance of the TLED-LB is evaluated in accordance with the parameters outlined and reported by LM-79 and LM-80 documents. Photometric data is tested to IESNA LM-79-08 standard by an independent testing laboratory. Lumen maintenance, L70 a measure of long term reliability, is determined for the light source, which consists of the LED and PSB sub-assembly as installed in the luminaire, is determined using LM-80 in situ thermal and reliability data as provided by the LED manufacturer in accordance with DOE/EPA standards.

Listing:

The TLED-LB is ETL certified under UL1598 specifications and listed for wet locations. IP65 rated

Warranty:

The TLED-LB LEDLITElogic series features a 5 year warranty.

SAMPLE PHOTOMETRICS

TLED-LB-64 Mounted at 10'

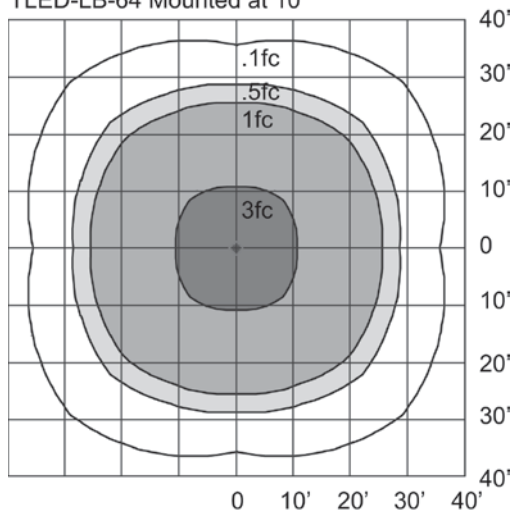

Fixture Performance					
Part Number	Initial Lumens	Lumens per Watt (LPW)	Total Watts	L70 Hours @ 25°C	BUG Ratings
TLED-LB-32-DT	3212	89	36	140,000	B2-U1-G1
TLED-LB-48-DT	4716	87	54	120,000	B3-U1-G1
TLED-LB-64-DT	6152	87	71	90,000	B3-U1-G1

NOTE: Lumen maintenance and life (part of LM-80 data) are per published information from primary LED suppliers and is based on design operation at their specified thermal management and electrical design parameters.

DIMENSIONS

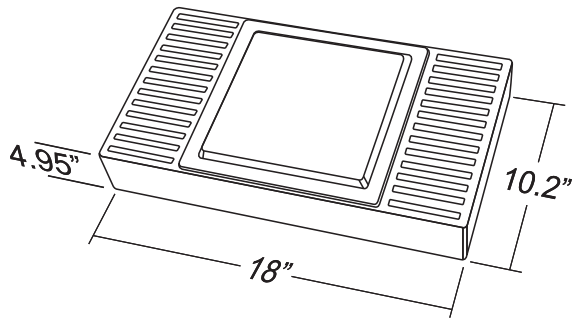

Approximate Weight: 28 lbs.

ORDERING INFORMATION

TLED-LB	36	DT	WH	TP	ACCESSORIES ¹ (Field Installed)
SERIES	# OF LEDES	INPUT VOLTAGE	HOUSING COLOR	OPTIONS ¹ (Factory Installed)	
TLED-LB	36 = 36 LEDES 48 = 54 LEDES 64 = 72 LEDES	DT = 120 to 277VAC	WH = White SLV = Silver	OCC/PC = Motion & Daylight Sensor	PC1 = 120VAC Photocontrol PC2 = 208-277VAC Photocontrol TLED-LB-WM/KIT = Vertical Wall Mount Kit

¹ Order As Separate Line Item



1911 West Parkside Lane • Phoenix, AZ 85027
888.533.3948 • 623.580.3948 • Fax: 623.580.8948
www.barronltg.com