



## Maintenance Instructions

Replace Ultraviolet lamp every **eight months** of use to maintain optimum performance of the unit.

By eight months the UV output of the lamp have lost approximately 30% of the effectiveness and should be replaced. After this time the lamp may still light but is no longer emitting enough of the special UV light frequency required for an effective insect catch.

### All other services:

Any servicing other than cartridge or UV lamp replacement, should be performed by an authorized service representative.

Call or Fax Paraclipse, Inc. for the name of the nearest service representative.

### Care and Cleaning of Unit:



For the best results your Insect Inn Ultra™ should be cleaned regularly when you change the cartridge.

When cleaning do the following:

1. Disconnect power cord from electrical outlet.
2. Use glass cleaner to clean the body of the trap and lamp. Make sure you remove excess insect droppings and dead carcasses.
3. Dry trap thoroughly with soft cloth.
4. Reconnect to electrical outlet.

### Always use a genuine Paraclipse replacement Quantum Lamp

For replacement parts contact your dealer. Call or Fax Paraclipse, Inc. for the nearest dealer.

### Replacement Parts and Part Number:

UV Quantum lamp	#72651
Cartridges (4 pack)	#73820
Shatterproof UV lamp	#72653

### To order additional Units:

Insect Inn Ultra Unit	#250501
-----------------------	---------

## Paraclipse®

Automated Insect Control Division  
 Paraclipse, Inc.  
 2271 East 29th Ave. PO Box 686  
 Columbus, NE 68602-0686 USA  
 Phone: (402)563-3625  
 Fax: (402) 564-2109  
 Email: paraclips@megavision.com  
 Web site: www.paraclipse.com  
 www.insectinn.com



# Paraclipse®

Automated Insect Control Division

## Insect Inn Ultra™



### SAVE THESE INSTRUCTIONS



### Insect Inn Ultra™ is their fatal attraction

#### 12 - Features

- Research- proven, flying insect attracting UV light device
- Exclusive automatic advance 60 day cartridge trapping system
- Large capacity disposable cartridge
- Specially engineered reflective top shell
- Front UV light slots
- Stylish unit can be placed in public areas
- End of cartridge alarm
- Highly effective combination of special UV light, attractants, and trapping surface
- The trapping system is environmentally friendly - unit has been designed for use in food handling areas, and meets applicable guidelines.
- Easy to maintain, easy to clean
- Unique cartridge placement-directly under bulb(s)
- Ultraviolet Light Booster Reflector

#### 12 - Benefits

- Effective attraction of flying insects already inside the building
- Eliminates large quantities of flies. Sanitary handling
- Holds up to 10 times the capacity of glue boards
- Directs light out and down, to increase overall effectiveness. Unit can be used on any color of wall for maximum effectiveness
- Helps direct UV light downward to attract more flies
- Your customers never know it's a flying insect trap
- Audible alert to replace used cartridge
- Draws flying insects to trapping surface - keeps them trapped
- No hazards to your customers from chemicals or unsanitary scatter of insect parts
- Effective flying insect control that doesn't make extra work for you or your staff
- Flies more quickly caught during random flight near bulb(s). Cartridge warmed from beneath draws more flies to catch surface.
- Increases the outward reflective power of the UV bulb(s)

Mounting Instructions

Page 4

Ultraviolet Lamp/Cartridge Installation

Page 5

Cartridge Alarm

Page 6

Manual Paper Advance

Page 6

Cover Installation

Page 7

Maintenance

Page 7 & 8



## Maintenance Instructions

### Cover Installation:

1. Plug in unit to verify that the lamp is operational.

Ultra Top Cover

Fig. 8

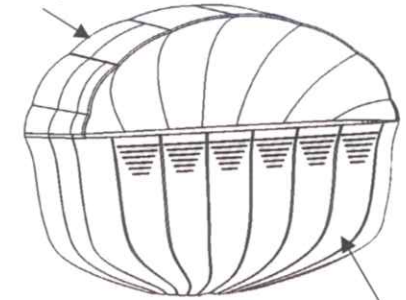

Ultra Bottom Cover

### Top & Bottom Cover Assembly:

1. Fig. 9 is a back view of the Ultra cover shells attachment features. The top & bottom cover have slide attachments for ease of assembly, disassembly, and ease of cleaning. After top & bottom are assembled, the Back Frame (Fig.10) has two ears, that fit into slots on bottom of Ultra top cover. Simply set the assembled fixture on ears.
2. Attach the cover shell (Fig. 8 & 9)

**NOTE:** The drive spool will turn approximately 1/2 revolution per day (24 hours).

### Cartridge Maintenance:



**DEAD INSECTS ARE UNSANITARY**

The tacky surface of the Cartridge advances slowly and can regularly remain effective up to 60 days, depending on the volume of insect catch. (Fig. 10)

1. When surface is no longer available or you hear the audible beep then you need to replace the cartridge.
2. If the surface is filled with a heavy catch of insects, manually advance the cartridge so fresh surface is available. (See pg. 6)



### Ultraviolet Quantum lamp Replacement:

1. Disconnect power cord from electrical outlet.
2. Remove old lamp.
3. Insert new lamp and twist lamp 90° (see page 5, Fig. 3).
4. Reconnect to electrical outlet.

BACK VIEW  
Top & Bottom Slide Attachment

Fig. 9

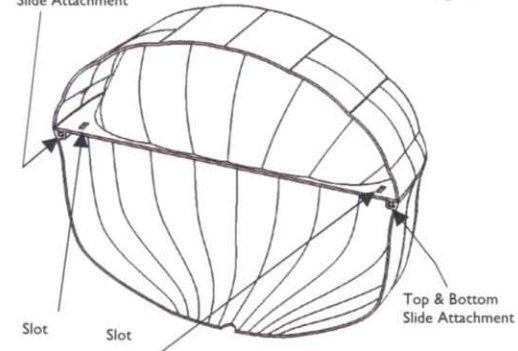

Slot

Top & Bottom Slide Attachment

Fig. 10

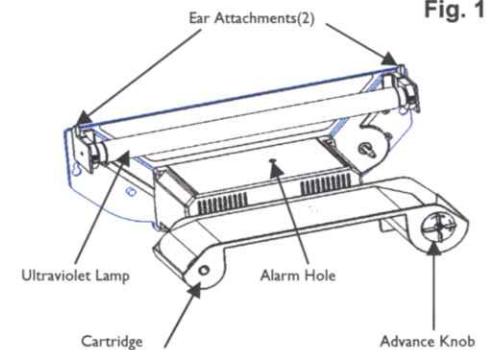

Ultraviolet Lamp

Alarm Hole

Cartridge

Advance Knob



## Cartridge Alarm & Manual Paper Advance

### Cartridge Alarm:

The Insect Inn Ultra™ has an out of paper sensor that emits an audible beep when it is time to replace the cartridge. (Fig. 6)

The alarm is triggered when the paper no longer covers the alarm hole in the top of the paper holder plate. An electronic light sensor recognizes this and begins to emit a high pitched beep.

#### Testing:

To test the operation of the alarm follow these steps:

1. Plug the unit in to the outlet.
2. Carefully remove the cartridge. The alarm should emit an audible beeping.
3. Stop the alarm by installing a fresh cartridge.

**NOTE:** If new cartridge is not available for installation, unplug the unit to shut off the alarm until a replacement cartridge is available.

### Manual Paper Advance:

You can manually advance the tacky paper surface by simply turning the right advance knob **clockwise** until the desired amount of tacky paper is available to catch insects. (Fig. 7)

This maybe required when installing a new cartridge and advancing the paper due to heavy insect catch.

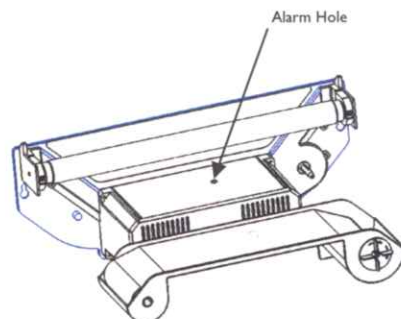

Fig. 6

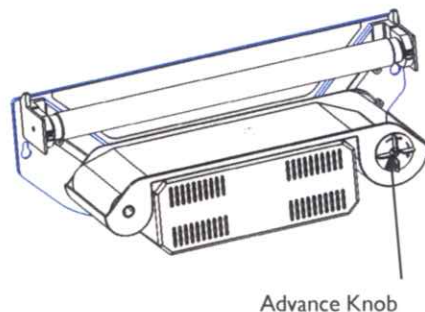

Fig. 7



## IMPORTANT SAFETY INSTRUCTIONS



This symbol is intended to alert you of the presence of dangerous voltage within the unit's enclosure that maybe of sufficient magnitude to constitute a risk of electric shock.



This symbol is intended to alert you of the presence of important operating and maintenance instructions accompanying the unit.

### Caution! To reduce the risk of electric shock, observe the following:

1. Do not remove the motor enclosure. No user serviceable parts are inside.
2. This product is intended for indoor use only! Do not use where it may be exposed to flammable vapor, explosive dust, water or direct sunlight (including roofed but open porches).
3. Disconnect the product from power supply when not in use, before servicing, cleaning, or when changing lamps.
4. Use only extension cords marked SPT- 1, or equivalent. Its electrical rating must be at least 120 V, 60 Hz, and 10 Amps. Use only extension cords which have plugs and receptacles which accept product's plug.
5. Replace or repair damaged cords.
6. Don't abuse the cord. Never carry the product by the cord or yank it to disconnect it. Keep the cord from heat, oil, and sharp edges. Main plug should always be accessible.
7. Extension cords & devices for retaining an extension cord connection to the power supply cord are available at most hardware stores.
8. Keep of the reach of children.

### HG—LAMP CONTAINS MERCURY

Manage in Accordance with Disposal Laws

See: [www.lamprecycle.org](http://www.lamprecycle.org) or call 1-800-435-4448

CAUTION! To avoid risk of contamination, observe the following: Dead insects are unsanitary. Use care in removing used cartridge.

## SAVE THESE INSTRUCTIONS



## Mounting Instructions

### Insect Inn Ultra contents:

- One Ultra Cover Shell Top
- One Ultra Cover Shell Bottom
- One Wall Anchor Kit
  - Two drywall anchors
  - Instructions
  - Screws
- One Frame Assembly
- One Cartridge
- UV Quantum Lamp

### Unit location on wall:

Select a wall away from windows or competing light source. For best results, mounting holes should be located 66" (1.68m) above the floor (Fig. 1).

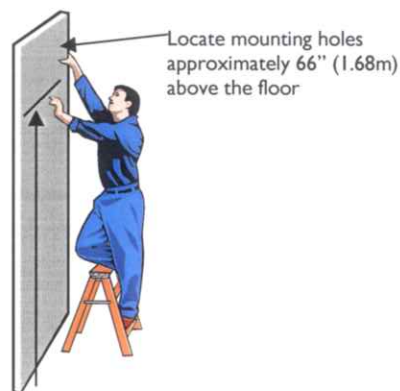

Fig. 1

### Mounting unit to wall:

1. As guide to hanging unit locate wall studs if possible. Mark two locations on the wall for your fasteners that are 16" (40.6 cm) apart. Make sure that the marks are level with each other.

#### a. Types of Fasteners that can be used:

- Drywall anchors
  - NOTE:** When using the drywall anchors follow the instructions provided in the Wall Anchor Kit.
- Two Screws
- Combination of one anchor and one screw
  - NOTE:** The wall anchor kit provided will accommodate these combinations.

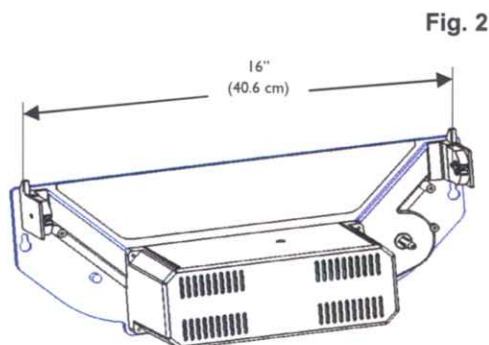
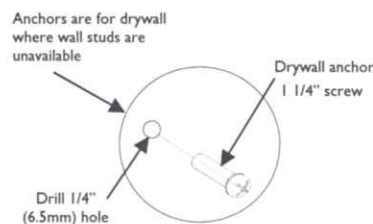

Fig. 2

2. Use a Phillips head screwdriver to mount the frame assembly on the wall. The frame assembly must be securely mounted to the wall
  - NOTE:** For other surfaces, such as concrete, different fasteners or anchors maybe required. These types of fasteners are not included.



## Ultraviolet Lamp/Cartridge Installation

### Lamp and Cartridge Installation:

**Note: Unit must be securely mounted to the wall before you proceed with the installation of Lamp & Cartridge**

1. Remove the ultraviolet lamp from the box. insert the lamp into the lamp sockets by aligning the pins of the lamp with the light socket and twist 90 degrees. (Fig. 3)

**NOTE:** It is recommended to replace the ultraviolet lamp every **eight months** of use to maintain optimum performance of the unit.

By eight months the UV output of the lamp has lost approximately 30% of the effectiveness and should be replaced. After this time the lamp may still light but is no longer emitting enough of the special UV light frequency required for an effective insect catch.

2. Rotate the drive spool of the cartridge in the direction of the arrow shown on the drive spool until the paper is adhered to itself on the drive spool. (Fig. 4)

**NOTE:** About 11 to 12 rotations will be required.

3. Position the cartridge on the front of the motor enclosure. Push the cartridge in until it stops. (Fig. 4 & 5)

**Replacement Quantum lamp: part # 72651**

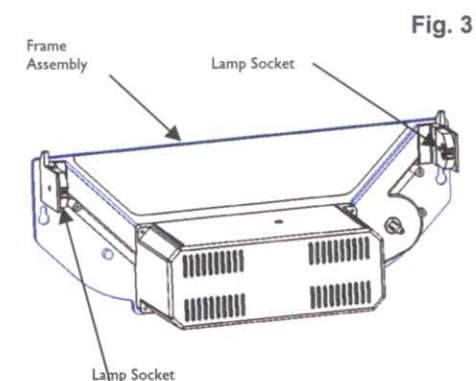

Fig. 3

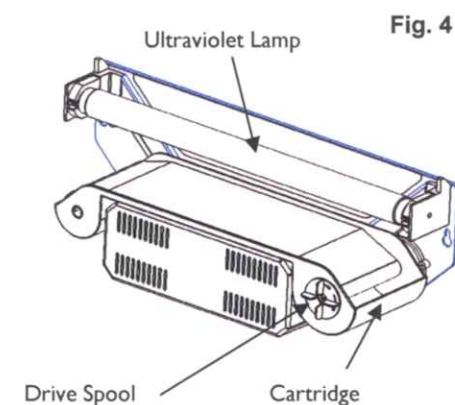

Fig. 4

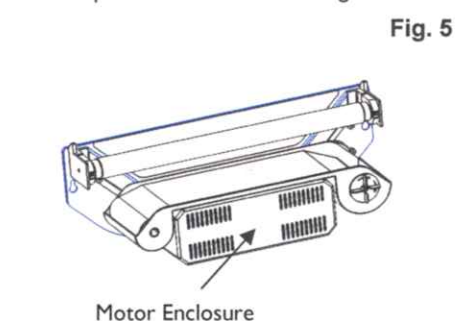

Fig. 5