



Precision Lamp & Transformer

PRODUCT SPECIFICATION BULLETIN

150W S55

High Pressure Sodium

150HX4TK

60 Hz HX-HPF

Input Volts	120	208	240	277
Line Current (Amps)				
Operating	1.60	0.85	0.80	0.70
Open Circuit	2.80	1.60	1.40	1.25
Starting	1.60	0.85	0.80	0.70
Regulation				
Line Volts	±5%	±5%	±5%	±5%
Lamp Watts	±10%	±10%	±10%	±10%
UL Temperature Ratings				
Insulation Class	H	H	H	H
Coil Temperature Code	D	B	C	C
Benchtop Coil Rise	86.3	79.6	83.9	83.5
Input Watts	188 W	188 W	188 W	188 W
NOM. Open Circuit Voltage	120	120	120	120
Power Factor	90%	90%	90%	90%
Current Crest Factor	1.50	1.50	1.50	1.50
Input Voltage At Lamp Dropout	95	180	190	225
MIN. Ambient Starting Temp.	-40°F -40°C	-40°F -40°C	-40°F -40°C	-40°F -40°C
60 HZ TEST PROCEDURES				
High Potential Test (Volts)				
1 Minute	2,000 V	2,000 V	2,000 V	2,000 V
1 Second	2,500 V	2,500 V	2,500 V	2,500 V
Open Circuit Voltage Test (V)	105 - 135	105 - 135	105 - 135	105 - 135
Short Circuit Current Test (A)				
Secondary Current Min	3.80	3.80	3.80	3.80
Max	4.70	4.70	4.70	4.70
Input Current Min	1.20	0.65	0.60	0.50
Max	1.85	1.00	0.95	0.80
Recommended Fuse (Amps)	7	4	4	4
CORE and COIL Specifications				
Dimension (A)	2.50 in	2.50 in	2.50 in	2.50 in
Dimension (B)	3.80 in	3.80 in	3.80 in	3.80 in
Weight (lbs.)	7.4 lb's	7.4 lb's	7.4 lb's	7.4 lb's
Lead Lengths	12"	12"	12"	12"
CAPACITOR Specifications				
Microfarads	14.0 uf	14.0 uf	14.0 uf	14.0 uf
Volts (min.)	280 V	280 V	280 V	280 V

3X4 CORE - HX, CWA & CWI UNITS

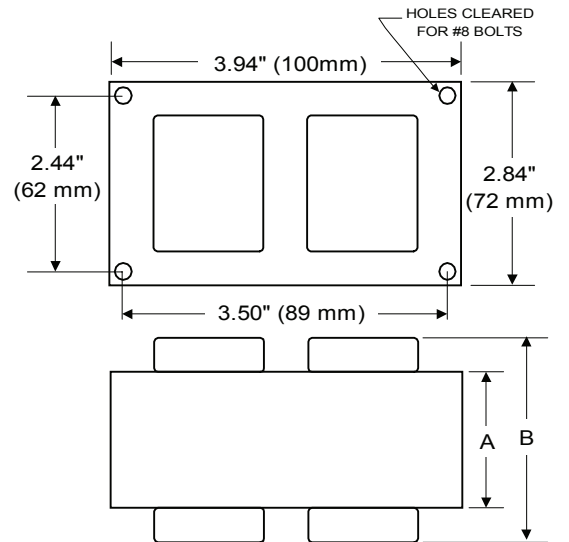

Capacitor: ACG309

Ignitor: BVS-006-A

Temp Rating: 100 °C
Height: 3.92 in
Dia/Oval Dim 1.38 in

Temp: 105 °C
BTL: 10 ft

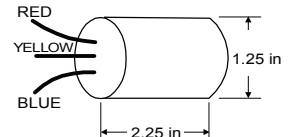
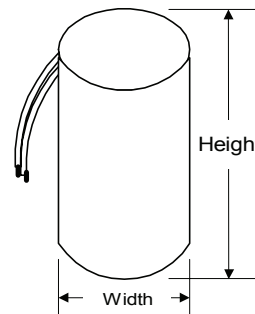

Plastic Dry Film Capacitor

Ordering Information Add Suffix for options

- C - With Capacitor
- K - With Capacitor and Bracket Kit
- B - With Welded Bracket no cap

Data is based upon tests performed in a controlled environment and is representative of relative performance. Actual performance can vary depending on operating conditions. Specifications are subject to change without notice

3/8/02

Production

