



NTM-5420 NTM-5430 NTM-5438

Ceramic Metal Halide (CMH) Lamp Holder

LAMP WATTAGE

- (1) CDM35/PAR20 (1) CDM35/PAR30L
- (1) CDM70/PAR30L (1) CDM70/PAR38
- (1) CDM100/PAR38

DESCRIPTION

Ceramic Metal Halide (CMH) gimbal and lamp holder. Utilizes electronic metal halide ballast designed for use with higher CRI Index MasterColor (or equivalent) PAR metal halide light sources.

FEATURES

- Electronic ballast
- Deep drawn steel socket cup housing for high strength and rigidity
- Heat resistant Teflon coated wire lead
- High-strength stainless steel electrical contacts
- One or two circuit track capable

HOUSING, SOCKET CUP

.025 Deep drawn steel construction with softened edges. "L" gimbal allows socket to be adjusted into any position for optimal lighting performance and fixture appearance.

BALLAST

Integral high power factor electronic solid state Type-1 ballast housed in .030 finished steel enclosure. Ballast provides automatic termination upon end of lamp life. i.e. "End of Life" protection.

Input Voltage:	120V
Power Factor:	>95%
Sound Rating:	A
Frequency:	170 Hz (square wave)
Min. Starting Temp.:	5°F (-15°C)
Total Harmonic Distortion:	<10%
Ballast Life Expectancy:	56,000 hours (at 75°C)
Input Power:	35W 70W 100W
Input Watts:	44 78 110
Operating Amps:	.37 .67 .90

SOCKET

4KV 660VA/600V Porcelain jacketed aluminum screw thread medium-base socket.

WIRING

Teflon coated wire lead connects socket and housing to electrical contact head. Teflon coating is durable and resists heat degradation from lamp and housing radiation.

CONTACT HEAD ASSEMBLY

Three .030 stainless steel contacts mounted in high heat rated plastic housing.

ONE/TWO CIRCUIT CONVERSION

Positive contact (opposite neutral and ground contacts) is preset to "down" position at factory, but may be raised to the higher position to install onto the second circuit of Nora Lighting NT-2300 series two-circuit track.

FINISHES

White or Black heat rated baked enamel paint. Custom painting or anodizing for special applications is also available. Custom finishes will require lead times that vary depending on vendor schedules. Please consult

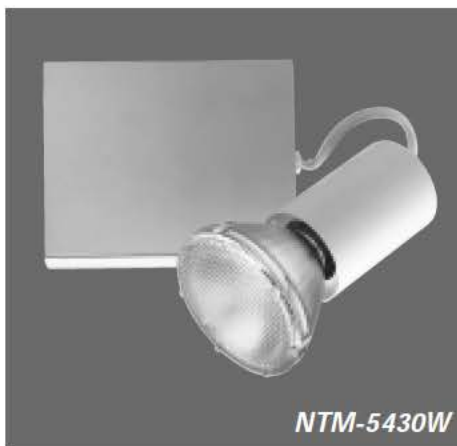

NTM-5430W



NTM-5438B

PRODUCT MATRIX

NTM-5420/35	B,W CDM35/PAR20 CMH Lamp Holder
NTM-5430/35	B,W CDM35/PAR30L CMH Lamp Holder
NTM-5430/70	B,W CDM70/PAR30L CMH Lamp Holder
NTM-5438/70	B,W CDM70/PAR38 CMH Lamp Holder
NTM-5438/100	B,W CDM100/PAR38 CMH Lamp Holder

DIMENSIONS

NTM - 5 4 2 0

A: Diameter	2-1/2"	(64 mm)
B: Length	4"	(102 mm)
C: Max Extension	7-3/8"	(187 mm)

NTM - 5 4 3 0

A: Diameter	3-3/4"	(95 mm)
B: Length	4-5/8"	(117 mm)
C: Max Extension	8-3/8"	(21 cm)

NTM - 5 4 3 8

A: Diameter	4-3/4"	(121 mm)
B: Length	5-5/8"	(143 mm)
C: Max Extension	9-3/4"	(25 cm)

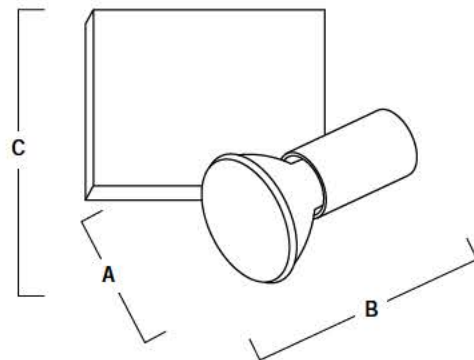

factory for quotation, and provide either a Dunn Edwards number or color chip for exact matching.

COMPATIBILITY

Nora track fixtures are interchangeable with Halo, Catalina, Hampton Bay, Halo-Edison, or any other brands configured to Halo track system design. *Note: fixtures may not be compatible with non-Nora transformers or monopoint adapters.*

UL LISTED

UL Listed as track lighting fitting

ACCESSORIES

Custom FinishesConsult Factory