

NTL-205 NTL-2205



MR16 High Tech Acrylic

LAMP WATTAGE

(1) 50MR16 12V GU 5.3 (not included)

DESCRIPTION

Line or low voltage aluminum designer fixtures with MR16 light source and beveled acrylic "antique" trim face. Yoke provides full adjustment of light source for special aiming and dual brass tightening knobs assure secure lock on angle position. Socket held in place by two rods and position is secured with two brass knobs, providing firm hold and additional design feature.

FEATURES

- Lightweight aluminum, plastic, and acrylic construction
- Low profile, aesthetic design
- Adjustable yoke for custom aiming
- Solid brass designer tightening knobs
- Clear shield included with fixture
- High-strength stainless steel electrical contacts
- One or two circuit track capable

HOUSING

.030 steel construction, combined with brass, acrylic, and plastic design details. .40 Square steel rod secures plastic socket cup and is held in position along twin .20 solid steel rods with brass tightening knobs. Tightening knobs are easily hand tightened, or may receive extra torque from a screwdriver to lock position.

GIMBAL RING

.030 Steel gimbal ring contains "antique glass" beveled acrylic face with decorative finished steel trim ring. Gimbal ring is permanently mounted to the socket cup via the twin steel rods mentioned under "Housing".

YOKE

.065 Rigid steel angled yoke connects fixture housing to electrical contact head. Dual brass designer knobs provide additional design feature and are tightened by hand or screwdriver.

TRANSFORMER

Solid state electronic transformers provide noise-free voltage reduction and operation. If dimming, use electronic low voltage rated only dimming controls.

NTL-205:

Integral Unit - 120V/60Hz Input; 12V Output; 50VA Max. Load

NTL-2205 (requires separate transformer):

External Unit - NTL-2200/50: 120V/60Hz Input; 12V Output; 50VA Max. Load

WIRING

Teflon coated wire lead connects socket and housing to electrical contact head. Teflon coating is durable and resists heat degradation from lamp and housing radiation.



NTL-205W



NTL-2205G

DIMENSIONS

NTL - 205

A: Diameter	3-7/8"	(99 mm)
B: Length	2-7/8"	(73 mm)
C: Extension	6"	(152 mm)

NTL - 2205 *

A: Diameter	3-7/8"	(99 mm)
B: Length	2-7/8"	(73 mm)
C: Extension*	7"	(178 mm)

* Extension includes NTL-2200 transformer which is required for use with NTL-2205

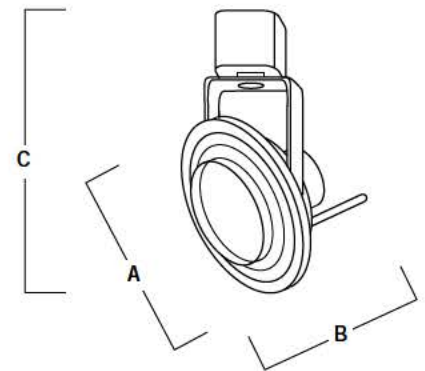

SOCKET

Porcelain socket for GU 5.3 12V MR16 lamp.

LAMP SHIELD

High temperature glass shield included. Mounted to front of lamp fixture and held in place with high-tension retaining spring clip.

CONTACT HEAD ASSEMBLY

Three .030 stainless steel contacts mounted in high heat rated plastic housing.

ONE/TWO CIRCUIT CONVERSION

Positive contact (opposite neutral and ground contacts) is preset to "down" position at factory, but may be raised to the higher position to install onto the second circuit of Nora Lighting NT-2300 series two-circuit track.

FINISHES

White or Black heat rated baked enamel paint. Accents on beveled face along with rods and yoke are also available in gold. Body and contact head housing are black finished with this option. Custom painting or anodizing for special applications is also available. Custom finishes will require lead times that vary depending on vendor schedules. Please consult factory for quotation, and provide either a Dunn Edwards number or color chip for exact matching.

COMPATIBILITY

Nora track fixtures are interchangeable with Halo, Catalina, Hampton Bay, Halo-Edison, or any other brands configured to Halo track system design. Note: fixtures may not be compatible with non-Nora transformers or monopoint adapters.

UL LISTED

UL Listed as track lighting fitting

ACCESSORIES

- Transformers (required for NTL-2205)
 - 50VA NTL-2200/50(B,W)
- Filters NM-110 (See accessories page)
- Custom Finishes ... Consult Factory

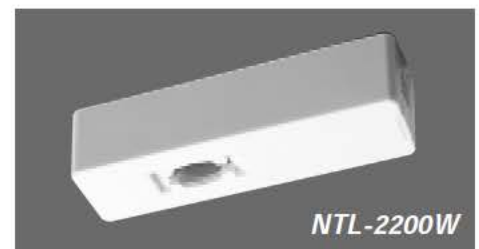

NTL-2200W