

# DCD26

Incandescent Dimmer

Installation Instructions



## SPECIFICATIONS

Voltage .....	120VAC, 60Hz
Operating Temperature.....	32°F to 104°F (0°C to 40°C)
Maximum Load Rating .....	600W
Minimum Load Required .....	40W
Load Type Compatibility.....	40-600W Incandescent (tungsten/quartz halogen)

US Patent 6,175,220. Other utility, design, and foreign patents pending.



legrand®



legrand®

## UNIT DESCRIPTION

The DCD26 incandescent dimmer controls incandescent lighting loads. Used in conjunction with Miro Decorator DCD68 multilocation controllers, the DCD26 offers control of a dimming circuit from multiple locations.

### Load Types

Use the Miro Decorator incandescent dimmer for these load types (40-600W at 120V):

- Incandescent and quartz halogen lamps



**Do not wire with conventional switches** as part of a 3-way or 4-way switching circuit.

**Do not mix different load types** on the same dimmer.

**Do not use with diode equipped** (some types of energy saving) lamps.



**Do not use to control motors.**

For dimmable, 2-wire fluorescent and compact fluorescent fixtures, electronic low voltage, magnetic low voltage, neon or cold cathode fixtures or diode equipped lamps, use the Miro DCD267 universal dimmer.

### Derating

When **more than one dimmer** is installed in a multi-gang box, it is necessary to reduce the maximum load on each dimmer:

- For a dimmer in either end position of a multi-gang box, reduce its maximum load by 100W.
- For a dimmer in a central position of a multi-gang box, reduce its maximum load by 200W.

 **CAUTION**   
**TURN THE POWER OFF AT THE CIRCUIT BREAKER  
BEFORE INSTALLING THE DIMMER.**

### Installation

For ease of installation, manufacturer recommends use of a deep wall box.

1. Disconnect power to circuit by turning circuit breaker OFF before installation.
2. Remove existing wall plate and switch.
3. Strip existing wires 1/2". If two wires will be connected to the same terminal on a Miro device, both wires must be the same gauge (12AWG or 14AWG).
4. If NEUTRAL wires are provided to the fixture, connect them together using a wire nut. The dimmer does not use a neutral connection.

**Select your application to continue...**

### Single Location

5. Wire the LINE (black), LOAD and GND supply wires to the correspondingly marked screw terminals, according to Figure 1. Does not use a neutral connection.

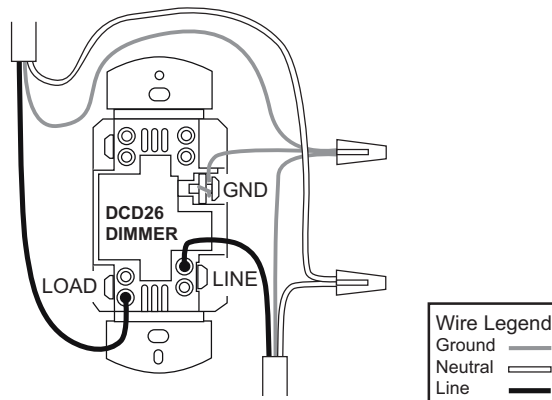

**Figure 1: Single location wiring**

## Two Locations

Use with one Miro DCD68 multilocation controller.

5. Install the DCD26 dimmer and the DCD68 controller, following the wiring diagram in Figure 2. The dimmer can go in either location. Use a 3-wire and ground cable to wire between devices. (In existing 3-way switched installations this wire is already in place.) The DCD68 requires a ground. Be sure to verify the ground connection.

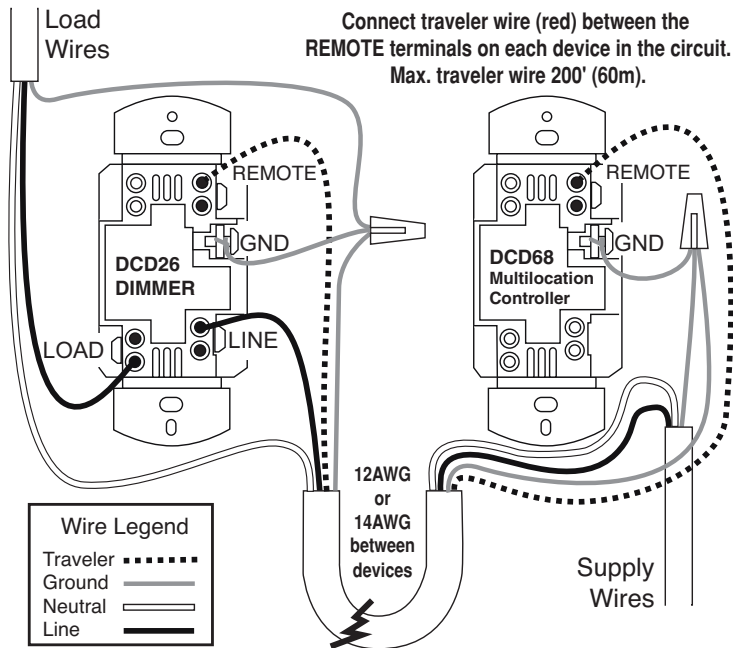

Figure 2: Two location wiring

### Three or More Locations

Use with two or more Miro DCD68 multilocation controllers, for multilocation control. **DO NOT WIRE WITH CONVENTIONAL SWITCHES AS PART OF a 3-WAY or 4-WAY SWITCHING CIRCUIT.**

5. Install the DCD26 dimmer and the DCD68 controllers, following the wiring diagram in Figure 3. The dimmer may be in any position in the circuit. Use a 3-wire and ground cable to wire between devices. (In existing 3-way switched installations this wire is already in place.) Be sure to verify the ground connection.

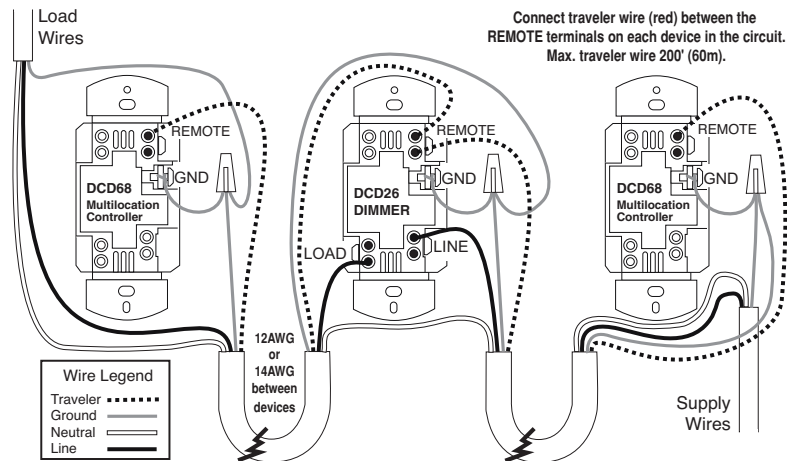

Figure 3: Wiring for 3 or more locations

### Finishing the installation

6. Attach the wall plate.
7. Switch the circuit breaker ON.
8. Make sure the LED on the DCD26 dimmer is lit. There is no LED on the DCD68 controller.

For ease of installation, manufacturer recommends use of a deep wall box.

**INSTALL IN COMPLIANCE WITH ALL APPLICABLE  
CODES & STANDARDS.**

Failure to follow these instructions may cause  
personal injury or equipment damage.

## OPERATION

↑	Tap once	Fade the circuit to its last-used level
↑↑	Tap twice	Full bright
-↑-	Press and hold	Increase the present level
↓	Tap once	Fade the circuit to OFF
-↓-	Press and hold	Decrease the present level

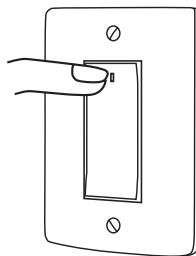

When you see ↑ in the instructions, touch the top of the switch as directed.

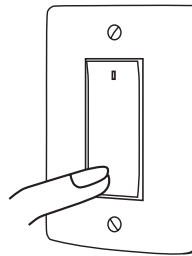

When you see ↓ in the instructions, touch the bottom of the switch as directed.

Note: The dimmer may feel warm to the touch during normal operation.

### Replacing Lamps

When a lamp must be replaced, use the Air Gap Isolation feature for safety. This feature is only available at the dimmer, which can be identified by its status LED. (The remotes do not have an LED and can not operate this feature.)

#### To activate the feature from the dimmer:

Press ↓ FIRMLY, so that the paddle clicks and latches in. Make sure the status LED is extinguished, indicating that it's safe to relamp.

To release and return to normal operation, press ↑.

### Power Fail Memory

After a power failure, all Miro devices automatically return to the state they were in immediately prior to loss of power.

## **Cleaning**

Clean using a cloth dampened only with water and a little mild detergent.

Use of solvents or hydrocarbon-based cleaners may cause permanent damage.

## **TROUBLESHOOTING**

### **In a multilocation circuit with one or more multilocation remotes, the dimmer works, but the multilocation remotes don't function.**

- This condition would exist if the LINE and LOAD connections are reversed. Check to make sure the connections are correctly terminated at the dimmer.
- The remotes require a ground connection. Check to make sure the ground wires are securely connected.

### **The Dimmer does not work and the status LED is flashing red**

- **at 1Hz (5 times in 5 seconds):**  
The dimmer has detected an unsuitable load. Remove power, check the load, restore power and try again.
- **at 2Hz (10 times in 5 seconds):**  
The dimmer has detected an overload condition and has shut down. Clear the fault condition by returning the unit to OFF, disconnect loads in excess of rated load and try again.
- **at 3Hz (15 times in 5 seconds):**  
The dimmer has detected a short-circuit condition and has shut down. Remove power, rectify the short-circuit condition, restore power, and try again.

## WARRANTY INFORMATION

Manufacturer warrants its products to be free of defects in materials and workmanship for a period of five (5) years. There are no obligations or liabilities on the part of Manufacturer for consequential damages arising out of, or in connection with, the use or performance of this product or other indirect damages with respect to loss of property, revenue or profit, or cost of removal, installation or reinstallation.

### Watt Stopper Customers contact:



2800 De La Cruz Blvd.  
Santa Clara, CA 95050  
Phone: 800.879.8585  
[www.wattstopper.com](http://www.wattstopper.com)

Please  
Recycle



05721r2 9/2007

### Vantage Customers contact:



1061 South 800 East  
Orem, UT 84057  
Phone: 800.555.9891  
[www.vantagecontrols.com](http://www.vantagecontrols.com)